

Rev No	Revision note	Date	Signature

Air Outlet
1-5/16"-12UN

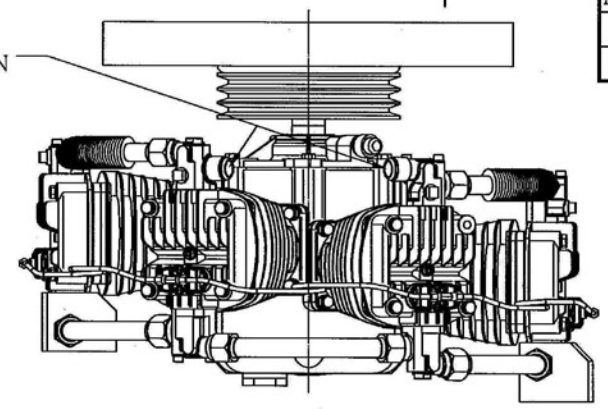

Model	Power Hp/kw	Working Press.	r.p.m.
P15	15/11	115 PSI	950

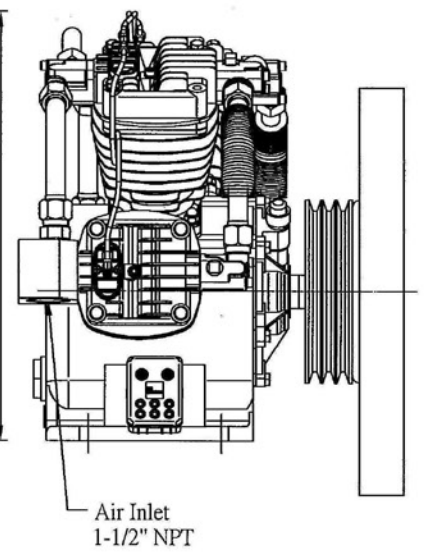
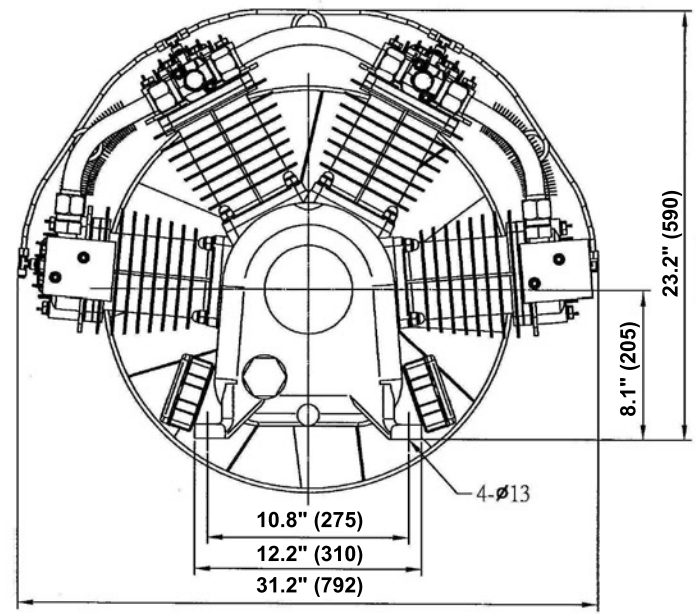
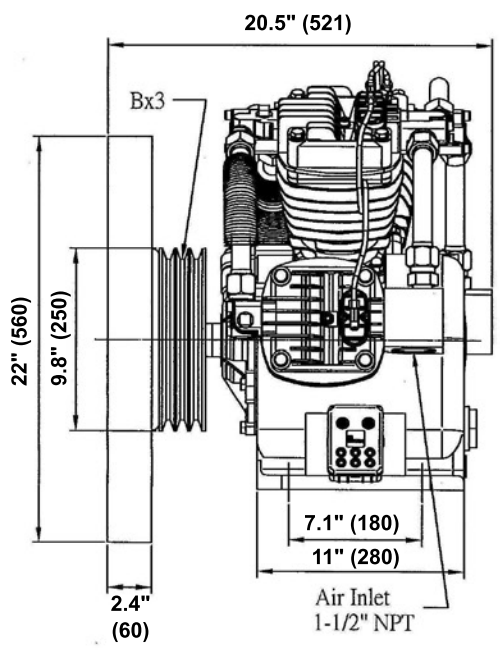

Usage Directives:

1. For compressing atmospheric air only. The air intake should be cool, clean, dry air and free from solid impurities and corrosive gases.
2. Strictly follow the parameter as specified.
3. Installation procedure:
 - 3.1 Ensure the floor is level and of sufficient strength.
 - 3.2 The belt guard must be equipped with and have a minimum 30cm clearance.
 - 3.3 Check the belt tension and alignment properly.
 - 3.4 The location should be dry and free from dust, humidity and aggressive or explosive gas.
4. Use only OMC genuine parts for servicing and maintenance.
5. Warranties are excluded if not operated in the intended way and do not conform with the users' manual directives.

	Date	Part Number	Description	Unit
	02/26/2015	230101	P15 OIL-LESS COMPRESSOR	IN (mm)