

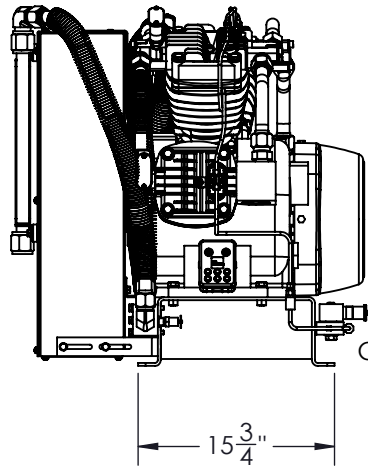

1" NPT AIR DISCHARGE

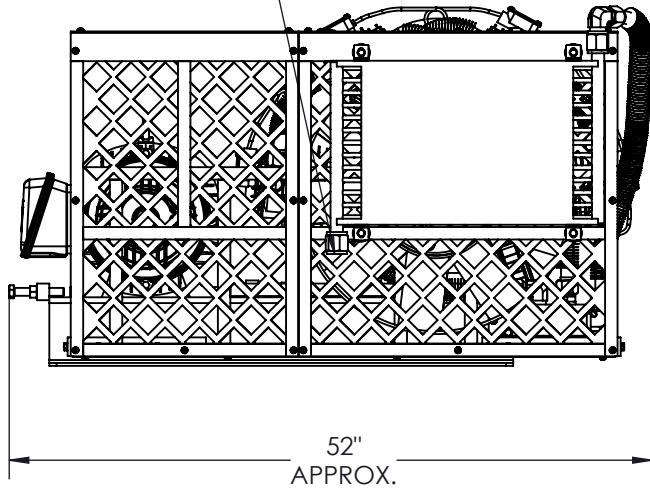

2" NPR AIR INLET CONNECTION

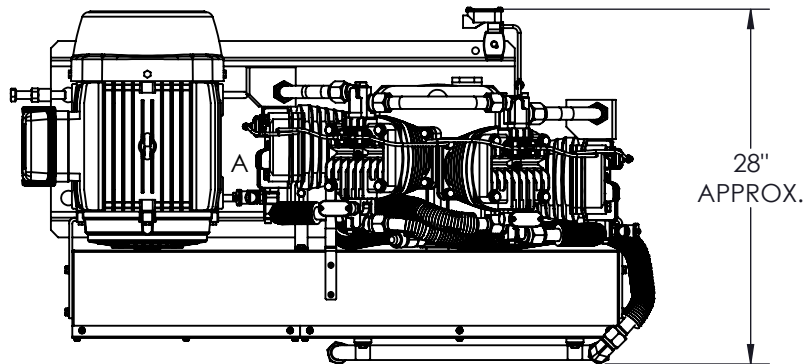
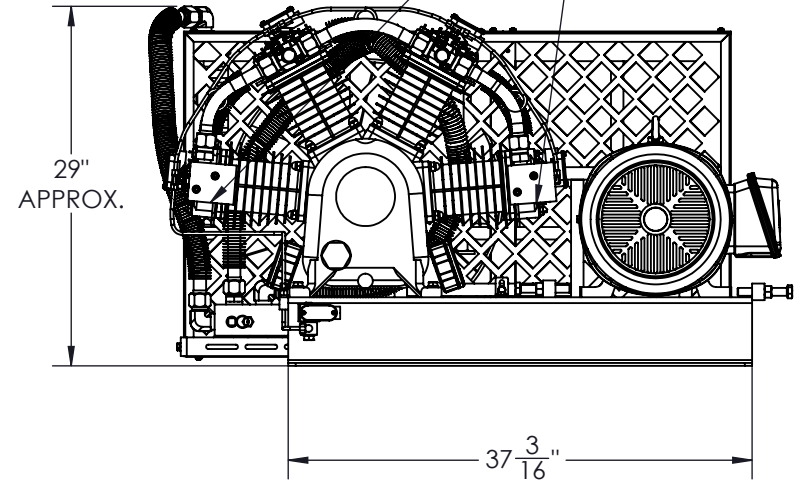

01	N/A	INITIAL RELEASE	12/05/11	F.L.
REV.	ECO NO.	DESCRIPTION OF CHANGE	DATE	BY
DO NOT SCALE DRAWING UNLESS OTHERWISE SPECIFIED; DIMENSIONS ARE IN INCHES AND TOLERANCES ARE: XX ± 0.1 XXX ± 0.01 XXXX ± 0.005 XX ± 1		DRAWN BY F. LOPEZ	DATE 12/05/11	 <small>COPYRIGHT &amp; COPYRIGHTED BY OHIO MEDICAL CORPORATION</small>
		CHECKED BY	DATE	
		APPROVED BY	DATE	
THIRD ANGLE PROJECTION		ITEM DESCRIPTION AIR COMPRESSOR MODULE, 15 HP RECIPROCATING AIR 208-230/460V		
MATERIAL N/A	DWG SIZE B		PART NUMBER P15-M	PART REV. 01
FINISH N/A	FILE NAME 100-0224.slddrw		SCALE: 1:16	SHEET 1 OF 1
<small>CONFIDENTIAL: THIS DRAWING AND THE DESIGN REPRESENTED THEREIN ARE THE PROPERTY OF OHIO MEDICAL CORPORATION AND HAS BEEN ISSUED WITH THE UNDERSTANDING THAT NEITHER DRAWING NOR THE INFORMATION THEREIN IS TO BE USED OR DISCLOSED, EITHER IN WHOLE OR PART, EXCEPT AS SPECIFICALLY AUTHORIZED BY OHIO MEDICAL CORPORATION AND SHALL BE RETURNED UPON REQUEST.</small>				