



# SELECTORR® Series Claw Vacuum Pump C30 Model

---

## Installation & Operation Manual



---

# **INSTALLATION & OPERATING MANUAL**

## **SELECTORR® SERIES CLAW VACUUM PUMPS C30**

Please read the manual before operating the vacuum pump.

### **TABLE OF CONTENTS**

<b>1.0 INSTALLATION</b>	<b>3</b>
1.1 General Description	3
1.2 Unpacking	3
1.3 Location	3
1.4 Power Requirements	4
1.5 Vacuum Connections	5
1.6 Oil Filling on Gear Box	5
<b>2.0 SAFETY</b>	<b>6</b>
2.1 General Notices	6
2.2 Warning Labels and Explanation	6
2.3 Location of Labels	6
<b>3.0 OPERATION</b>	<b>7</b>
3.1 Start-up	7
3.2 Stopping the Pump	7
3.3 Ambient Operating Conditions	7
<b>4.0 MAINTENANCE</b>	<b>8</b>
4.1 Pump Lube Oil (level, type, quantity, change)	8
4.2 Maintenance Chart	8
<b>5.0 PROBLEM SOLVING</b>	<b>9</b>
<b>6.0 TECHNICAL DATA</b>	<b>10</b>
<b>7.0 ASSEMBLY DRAWING AND PARTS LISTS</b>	<b>12</b>

---

## INSTALLATION AND OPERATING MANUAL

This manual covers the C30 contact-less operating claw type vacuum pumps. The model number is stamped into the nameplate with serial number: C30.

**Please identify the model number and serial number when ordering parts.**

### 1.0 INSTALLATION

#### 1.1 General Description

The C30 vacuum pump is a dry and contactless machine, enclosed in an acoustic sound shield, designed to have cooling air passed through the sound shield by a fan. The warm air is exhausted to the below compartment where the silencer is located. The C30 is built with modular construction consisting of two compartments: pumping and gear chambers separated by the use of labyrinth seals. In the pumping chamber, as two rotary claws rotate in opposite directions, the air is sucked in, compressed and discharged under pressure. In the gear chamber (box), two gears for synchronizing of the claws' rotation are lubricated with oil. The pumps are direct driven by a flanged motor via a coupling. The 4" aluminum check valve for anti suck back and inlet filter (flanged) can be installed separately. The C30 is well suited to use with Variable Frequency Controlled Drives for energy savings.

#### 1.2 Unpacking & Storage

Inspect the box and vacuum pump carefully for any signs of damage incurred in transit. Since all pumps are ordinarily shipped F. O. B. from our factory or regional warehouse, such damage is the normal responsibility of the carrier and should be reported to them.

The inlet and exhaust of the pump are covered with plastic caps to prevent dirt and other foreign substances from entering it. Leave these caps in place until you are ready to pipe the pump to your equipment.

The pump should be stored in a dry environment with normal air humidity (RH 0~80%, 14 to 140°F) for no more than 6 months.

#### 1.3 Location

Install the pump in a horizontal position on a level surface so that it can be evenly supported on its rubber feet.

Leave 8 to 10 inches of access around the pump to allow proper cooling. Also, adequate ventilation must be provided for cooling of the pump and motor.

Allow access to the oil sight glass in order to inspect the oil level regularly, and the oil fill and drain ports for easy service.

## 1.4 Power Requirements

A schematic diagram for the electrical motor terminal connections is located in the junction box of the motor or on the motor nameplate. Typical wirings for Three Phase Motors are as below:

### Wiring Scheme - Three Phase Motor

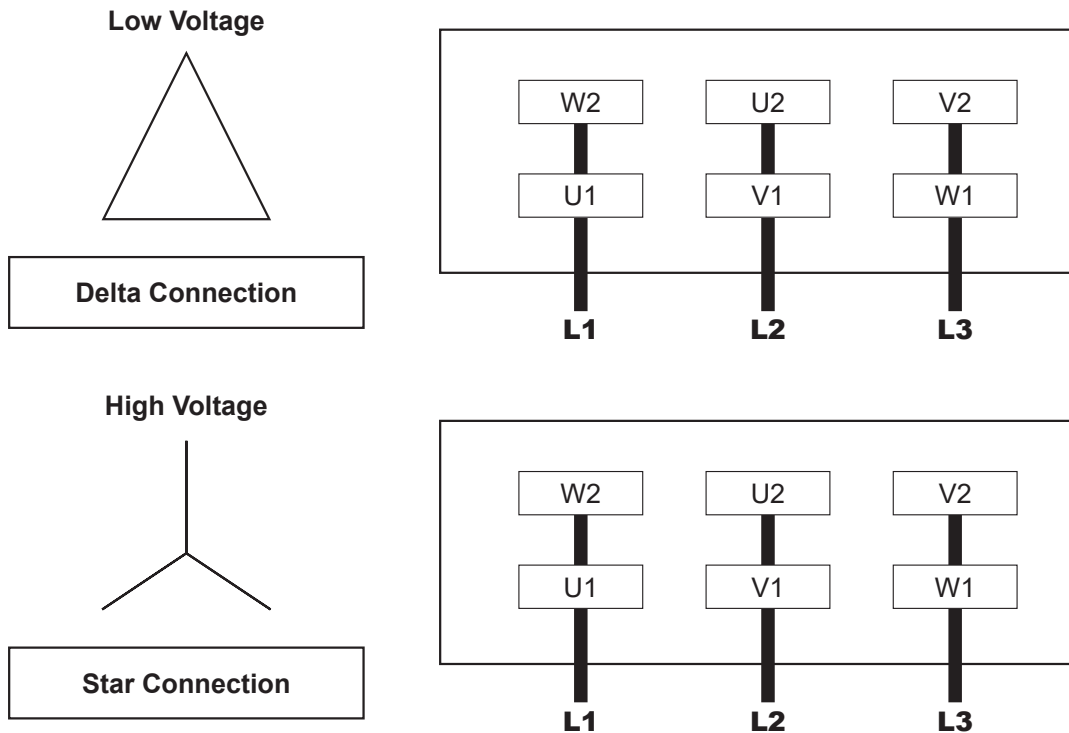

The motor must be connected according to the electrical codes through a fused switch in order to protect the motor against electrical or mechanical overload conditions. The overload of the motor starter must be set at a level equal to the full load motor current listed on the motor nameplate.

If the pump is supplied with a motor starter, it is preset at the factory according to customer specifications. It is advisable to check that these settings are in line with the voltage at your location. If the voltage is different, please contact Ohio Medical for motor and starter information.

Correct direction of rotation is marked by an arrow on the motor fan housing and is counterclockwise when looking at the motor from the motor's fan side.

*After electrical connections have been made, the rotation of the motor should be checked. If backward, reverse any two leads of the three at the power connection.*

## 1.5 Vacuum Connections

Use a pipe size that is at least the size of the pump inlet connections. Smaller lines result in reduced pump capacity.

Pumps operating in parallel on a common main line should have a manual or automatic operated shut-off valve or positive action check valve, installed in the suction line adjacent to the pump suction flange. The built-in anti-suck back valve should not be used as a shut-off valve for the vacuum system.

Remove the plastic protective cap from the inlet port prior to connection of pump to the system.

Should process gas contain dust or other foreign particles, a suitable inlet filter should be connected to the inlet port. Consult Ohio Medical for recommendations or refer to the “Vacuum Pump Filters” tab at [www.ohiomedicalparts.com](http://www.ohiomedicalparts.com).

The vacuum piping should be designed to ensure that no liquids such a condensate or liquid carried over from the process can reach the pump. If this possibility exists, a knock-out liquid separator should be installed. Consult Ohio Medical for recommendations or refer to the “Vacuum Pump Filters” tab at [www.ohiomedicalparts.com](http://www.ohiomedicalparts.com)

The following flange sizes are standard on the pumps:

Pump Models	Inlet Size	Exhaust Size
C30	4”	4”

## 1.6 Oil Filling on Gear Box

The pump is shipped without oil in the gear box. After level installation and correct rotation has been established, fill the pump with recommended gear oil through the oil fill port. Oil level should be over 3/4 position on the oil sight glass as shown on the label.



We recommend ISO VG150 gear oil or equivalent oils.  
Ohio Medical gear oil in 1-gallon container—part # 249225

The following provides the approximate amount of oil required for each model.

Pump Model	Capacity (Quart)
C30	3.4

**Do not add oil with vacuum pump running! Do not overfill.**

---

## 2.0 SAFETY

Please read the following safety notice carefully before operating the pump.

### 2.1 General Notices

- Thoroughly familiarize yourself with this installation and operating manual before operation.
- Only authorized and trained operators should operate the vacuum pump.
- If the pump is not properly working, it should be stopped immediately.
- Ohio Medical shall have no liability for any accident or failure arising from non-compliance with instructions in this manual.

### 2.2 Warning Labels and Explanations

Following warning labels are shown and attached on the C30 vacuum pump.

#### 2.2.1 Read and Understand manual:

Read and understand operator's manual before using this machine.

#### 2.2.2 Burn Hazard:

Hot surface. Do not touch.

#### 2.2.3 Loud noise Hazard

Loud noise hazard. Ear protection must be worn.

#### 2.2.4 Hazardous Voltage:

Disconnect power before opening. Contact causes severe electrical shock



### 2.3 Location of the Labels

The labels of 2.2.1 Read and Understand manual, 2.2.2 Burn Hazard, and 2.2.3 Loud noise Hazard shall be shown on the top of sound shield of the pump.

The label of 2.2.4 Hazardous Voltage shall be shown on the cover of motor's terminal box.

---

## 3.0 OPERATION

### 3.1 Start-up

Check rotation of the motor as described in paragraph 1.4 Power Requirements.  
Fill the pump with oil as described in paragraph 1.5 - Oil Filling

Start the pump with the inlet closed. Run the pump for a few minutes and then shut down. Check the oil level again and make sure the oil level is over 3/4 position of oil sight glass as shown on the label.

Add oil though oil fill port, if necessary. Pump oil should only be added when the pump is off

### 3.2 Stopping the Pump

To stop the pump, turn off the power. An anti-suck back valve (built-in) for these pumps installed in inlet flange will prevent the air from back flowing into the vacuum chamber after the pump is shutdown.

**Caution: In applications, where the quantity of water vapor is moderate, it is recommended to run the pump for 10 minutes at least with outside air prior to shut down to prevent the vapor from condensing in the pump.**

### 3.3 Operating Conditions

The C30 are designed to run the ultimate vacuum levels stated in technical data (6.0) for continuous operation. Operation over maximum vacuum level may result in failure of and severe damage to the machine.

Vacuum Regulator installed in inlet flange is set at maximum allowable vacuum at factory, and a desired vacuum level to below the maximum level can be achieved by rotating the adjustment knob.

The standard version is for use of dry air only, and may not be used in hazardous areas. Handling of humid air or gases containing aggressive chemicals is possible only with specially configured units. Consult Ohio Medical for assistance.

Excessive back pressure on the unit may result in excessive current draw.  
Do not operate the vacuum pump over 2 psi back pressure.

Also it is recommended for operating personnel who are working near the pump to wear ear protectors. If noise below the designed dBA is required, an external sound enclosure can be added to the system, provided adequate ventilation is provided.

The ambient and suction air temperature must be between 40°F and 104°F.

**Caution: Any non compliance may lead to severe injury to persons and damage to the pump.**

**Caution: Maximum number of motor starts per hour should not exceed 10 per hour. Excessive starting of the motor can cause overheating and premature failure of the motor. A minimum run timer should be used with any panel that may control the pump with automatic starts and stops based on system pressures.**

---

## 4.0 MAINTENANCE

The C30 vacuum pump requires very little maintenance. To ensure optimum performance, the following maintenance steps should be followed:

### 4.1 Gear Box Oil

#### 4.1.1 Oil Level

Check the oil level on a monthly basis. Under normal circumstances, it should not be necessary to add oil between oil changes. A significant drop in oil level means there is an oil leak. Please check the O-rings, drain plug or oil sight glass.

Check the oil level only when the pump is shut off. Replenish oil if it drops below bottom position of the sight glass.

Caution: Do not add oil while the pump is running, since hot oil can escape from the oil fill port.

#### 4.1.2 Oil Type and Quantity

See section 1.5 - Oil Filling - for details on oil type and capacity.

#### 4.1.3 Oil Change

Under normal ambient conditions with proper Gear Oil, it is recommended to change the oil every 3,000 operating hours or every 6 months. It is necessary to make the first oil change between 500 ~1000 operating hours.

### 4.2 Maintenance Chart

<b>Weekly</b>	Check inline inlet filter element / mesh. More often if high particulates in inlet stream.
<b>Monthly</b>	Check the oil level, protective mesh.
<b>Semi-Annually</b>	Check fans and coupling.
<b>Annually</b>	Check bearings / shaft seals / vacuum regulator. More frequently if operated at ambient temperature exceeding 68°F.
<b>Every 3000 Operating Hours</b>	Change the oil in the gear box.



Inspection hole with G1" plug: Check the coupling and its insert, and fan through this hole regularly.



---

## 5.0 PROBLEM SOLVING

5.1 Problem: The pump does not reach capacity.

5.1.1 Possible Cause: Inlet screen (mesh) of the inlet filter clogged with debris.

**Remedy:** check inlet filter element and clean screen (mesh) by compressed air or wash it.

5.1.2 Possible Cause: Pipe work is too long or small.

**Remedy:** Use a bigger diameter pipe and shorten the lines length if possible.

5.2 Problem: The pump runs over set pressure.

5.2.1 Possible Cause: Inlet screen (mesh) in the vacuum regulator clogged with debris.

**Remedy:** Clean screen (mesh) and check inlet filter element.

5.2.2 Possible Cause: Vacuum regulator set over the set point or is out of order.

**Remedy:** Set the point again or replace it with new regulator.

5.3 Problem: Vacuum pump does not reach the set pressure.

5.3.1 Possible Cause: Leak on the pump or system.

**Remedy:** Check the leak on the pump or system.

5.4 Problem: The pump is extremely noisy.

5.4.1 Possible Cause: Contamination of the claws or chamber.

**Remedy:** Clean the pumping chamber and the claws.

5.4.2 Possible Cause: Coupling insert is worn.

**Remedy:** Replace coupling insert in motor/pump coupling.

5.4.3 Possible Cause: Bearing noise.

**Remedy:** Replace bearings or call service agent for service or exchange program.

5.4.4 Possible Cause: Vacuum regulator noise.

**Remedy:** Replace vacuum regulator.

5.5 Problem: The pump will not start.

5.5.1 Possible Cause: Supply voltage is not proper or is overloaded. Motor starter overload settings are too low or improper; fuses are burned; wire size is too small or too long causing a voltage drop.

**Remedy:** Check voltage supply; overload settings in motor starter for size and settings according to motor nameplate. Install proper size wire. If ambient temperature is high, use the next larger size overloads, or adjust settings 5% above motor nameplate value.

**Remedy:** Repair or replace if needed or call service agent for service or exchange program.

5.6 Problem: The pump is running abnormally hot.

5.6.1 Possible Cause: Not enough air ventilation to pump.

**Remedy:** Make certain a sufficient amount of fresh air is supplied to the pump. Check for dirty or blocked mesh, clean mesh as necessary.

5.7 Problem: The pump will not operate (seized up).

5.7.1 Possible Cause: Rotary claws, bearings or gears stuck on.

**Remedy:** Call service agent for service or exchange program.

## 6.0 TECHNICAL DATA

VACUUM APPLICATION SPECIFICATIONS		
<b>Model</b>	<b>C30</b>	
<b>CFM</b>	60 HZ	670
	50 HZ	558
<b>HP</b>	60 Hz	30
	50 HZ	25
<b>RPM</b>	60 Hz	3450/2850
	50 HZ	
<b>dB(A), Max +- 3 tolerance</b>	60 Hz	85
	50 HZ	82
<b>Ultimate Vacuum Maximum</b>	26 inHg	
<b>Ultimate Vacuum Continuous</b>	24 inHg	
<b>Voltage Available</b>	220~240/380~420V x 50/60Hz, 400/690Vx 50Hz, 208~230/460V x 60Hz	
<b>Oil Capacity (Gear box)</b>	1½" quarts	
<b>Inlet / Outlet Connection</b>	4" flange	
<b>Ambient Operating Temperature</b>	41-104° F	
<b>Pump Weight (without motor)</b>	1730 pounds	
<b>Accessories</b>	Non Return Valve, Vacuum Regulator, Exhaust Silencer, Inlet Filter 4" Flanged	

# C30 CLAW VACUUM PUMP WITH 30 HP NEMA 286TC MOTOR

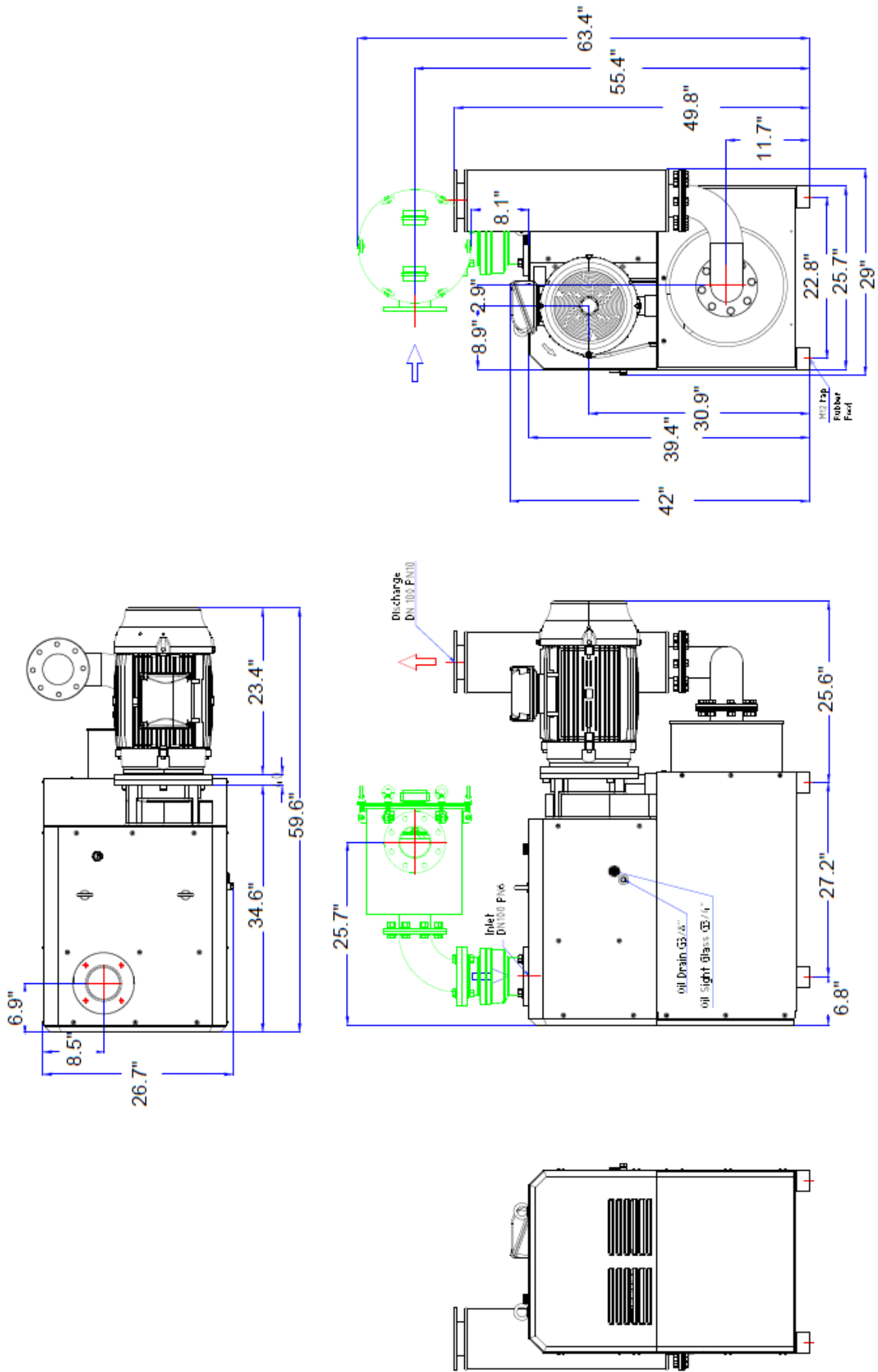

# ASSEMBLY DRAWING C30

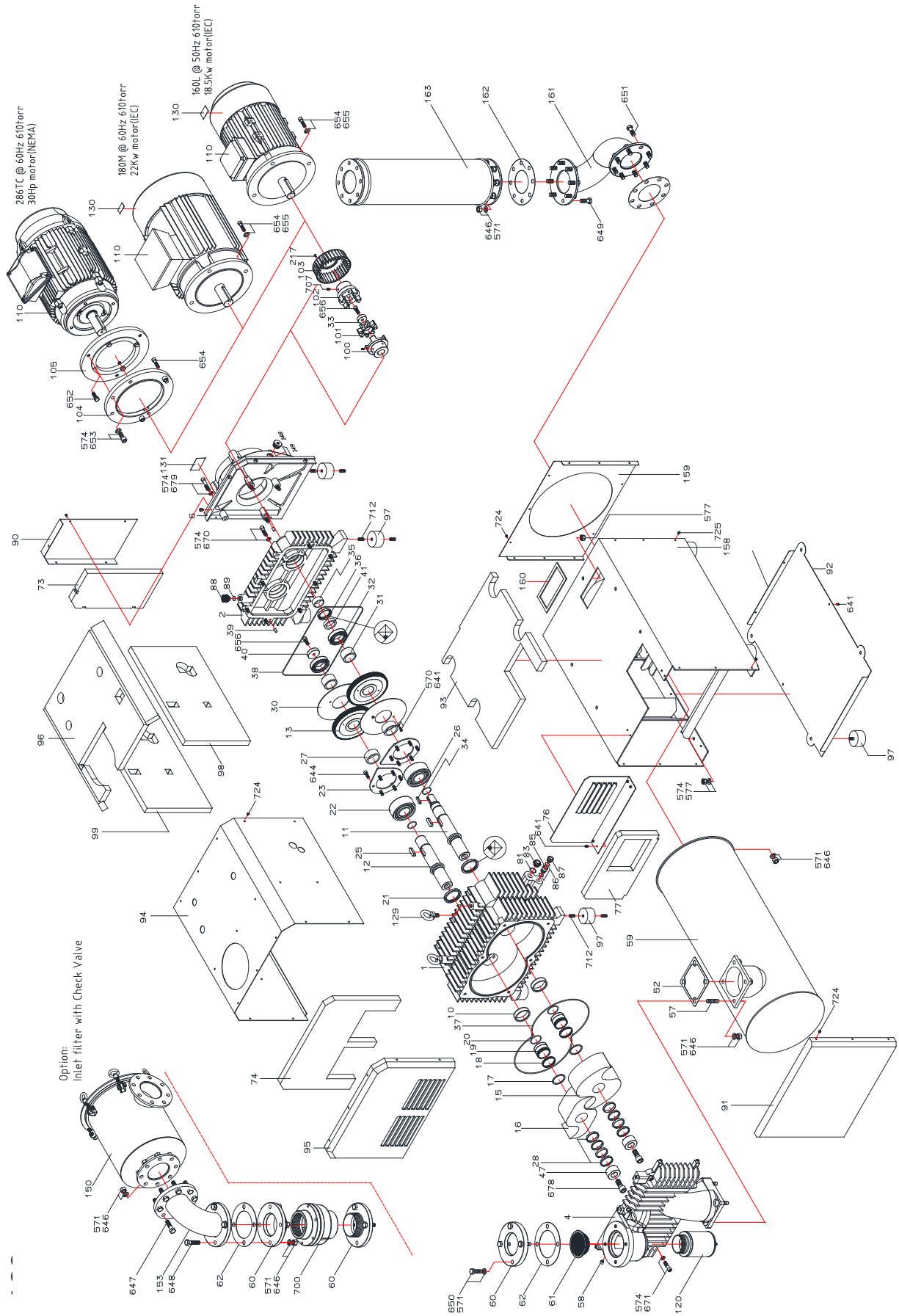

## C30 PART LIST

POS #	Description	Qty						
1	Gear Box Housing	1	62	Gasket, Inlet Flange	1	163	Silencer Inline	1
2	Gear Box Cover (rear)	1	73	Accoustic Mat for Shield Cover, End	1	217	Round Head Bolt / M5 x 12	5
4	Pump Housing Cover 1 (End Plate)	1	74	Accoustic Mat for Shield Cover, Front	1	570	Washer, Spring Lock, 6mm	4
6	Fan Housing	1	76	Plate (vertical)	1	571	Washer, Spring Lock, 16mm	24
10	Sleeve	2	77	Accoustic Mat	1	574	Washer, Spring Lock, 12mm	27
11	Shaft 1	1	81	Gasket, Oil Sight Glass	1	577	Hexagon Nut M12	5
12	Shaft 2	1	83	Oil Sight Glass	1	641	Hex. Socket Head Cap Screw / M6 x 12	10
13	Gear	2	85	Pipe, for Drain Plug	1	644	Hex. Socket Head Cap Screw / M10 x 15	12
15	Rotor 1	1	86	Gasket, Drain Plug	2	646	Hexagon Nut M16	20
16	Rotor 2	1	87	Drain Plug	1	649	Hexagon Bolt / M16x40	8
17	Spacer	2	88	Oil filler Breather, Plastic	1	650	Hexagon Bolt / M16x40	4
18	Piston Ring	4	89	O-Ring for Oil filler, for PN 100.088.00	1	651	Hexagon Bolt / M16x40	8
19	Sleeve	2	90	Shield Cover, End	1	652	Hexagon Bolt / M16x50 (NEMA)	4
20	O-Ring	2	91	Shield Cover, Bottom Front	1	653	Hex. Socket Head Cap Screw / M12 (NEMA)	4
21	Shaft Seal 65x85x9t	2	92	Shield Cover, Bottom	1	654	Hex. Socket Head Cap Screw / M16x45	4
22	Bearing,	2	93	Accoustic Mat for Shield Cover, Base	1	655	Washer, Spring Lock, 12mm	4
23	Bearing cover	2	94	Shield Cover, Side	1	656	Hex. Socket Head Cap Screw / M12 x 25	2
25	Key, for Gear	2	95	Shield Cover, Front	1	670	Hex. Socket Head Cap Screw / M12 x 40	8
26	Key, for Coupling	1	96	Accoustic Mat for Shield Cover, top	1	671	Hex. Socket Head Cap Screw / M12 x 50	6
27	Sleeve	2	97	Foot, Rubber	9	678	Hex. Socket Head Cap Screw / M20	2
28	Power Lock	4	98	Accoustic Mat for Shield Cover, side (Right)	1	679	Hex. Socket Head Cap Screw / M12 x 70	4
30	Flinger	2	99	Accoustic Mat for Shield Cover, side (left)	1	707	Set Screw / M8 x 15	4
31	Sleeve,	2	100	Coupling, Pump Side	1	712	Set Screw / M12	14
32	Bearing	2	101	Insert, Coupling	1	724	Botton Flange Bolt M5x8	26
33	Locking Disk (Coupling)	1	102	Coupling, Motor Side	1	725	Botton Flange Bolt M5x12	12
34	O-Ring	1	103	Fan, New	1	Option: Inlet Filter with Check Valve		
35	Sleeve,	1	104	Flange Adapter fan housing side (NEMA)	1	60	Inlet Flange, welded Nipple / DN100 PN6	2
36	Shaft Seal, 52x68x10t	1	105	Flange Adapter motor side (NEMA)	1	62	Gasket, Inlet Flange	2
37	O-Ring, Compressor cover,	1	110	Motor	1	150	Inlet Filter IF-400	1
38	O-Ring, Gear Box cover,	1	120	Vacuum Regulator	1	153	Elbow with Flanged DN100 PN6 + DN100 PN10	1
39	Dowel Pin ø10x30	4	129	Eye Bolt M16	2	571	Washer, Spring Lock, 16mm	12
40	Locking Disk	1	130	Label, Direction Arrow	1	646	Hexagon / Nut M16	12
41	Sleeve,	1	131	Name Plate	1	647	Hexagon Bolt / M16x50	8
47	Locking Disk, Front	2	148	Plug G-1", Inspection hole	1	648	Hexagon Bolt / M16x60	4
52	Gasket, Exhaust Silencer, Steel Silencer	1	149	Label, Inspection hole	1	700	Check Valve, CV-100	1
57	Stud M16x40	4	158	Base	1			
58	Rubber Buffer	13	159	Cover, Exhaust	1			
59	Silencer assembly steel	1	160	Seal	1			
60	Inlet Flang	1	161	Flanged Pipe	1			
61	Inlet screen (Conical )	1	162	Gasket, Silencer Inline	2			



**North America  
United States**

**Customer Service, Distribution Center  
Technical Support, Sales and Service  
Equipment Service Center**

Ohio Medical LLC  
1111 Lakeside Drive  
Gurnee, IL 60031 USA  
+1 (866) 549-6446  
[www.ohiomedical.com](http://www.ohiomedical.com)

Maintenance parts for your claw vacuum pump are listed at:  
<https://www.ohiomedicalparts.com/products/rotary-claw-vacuum-pumps-oil-less.php>

© 2020 Ohio Medical LLC. This document contains information that is proprietary and confidential to Ohio Medical LLC. Use of this information is under license from Ohio Medical LLC. Any use other than that authorized by Ohio Medical LLC is prohibited. Ohio Medical, the Ohio Medical logo, are registered trademarks of Ohio Medical LLC.