

Model	Power Hp/kw	Working Press.	r.p.m.
P3	3/2.2	115 PSI	700

Rev No	Revision note	Date	Signature

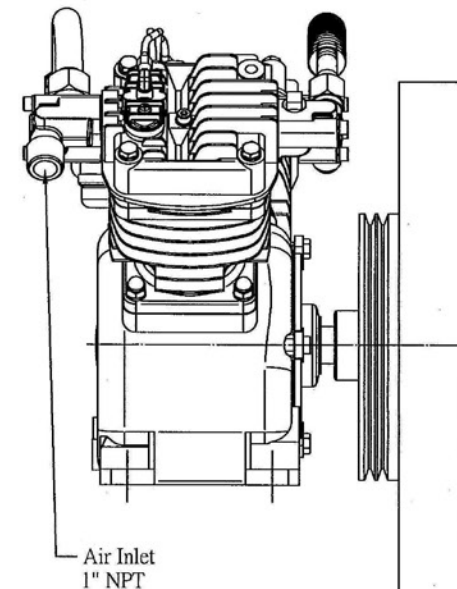
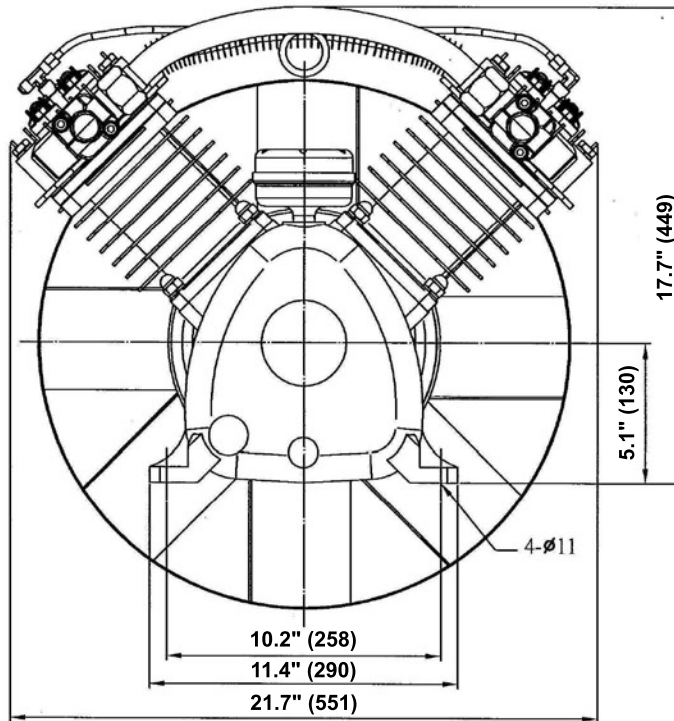
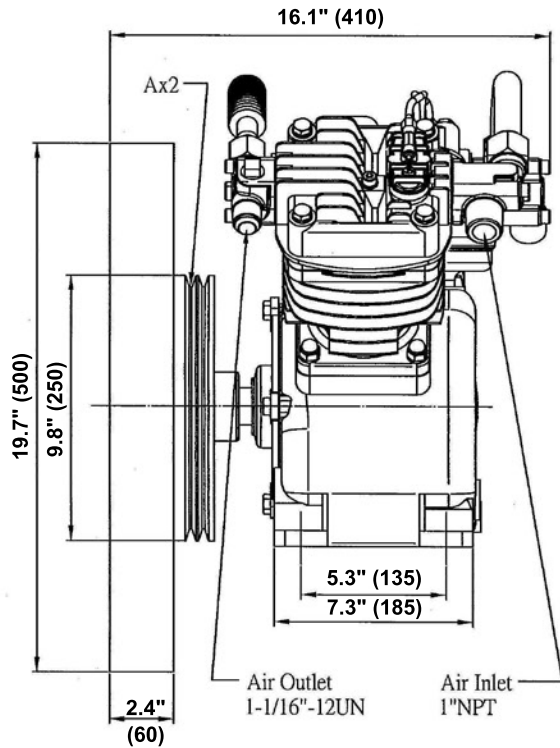

Usage Directives:

1. For compressing atmospheric air only. The air intake should be cool, clean, dry air and free from solid impurities and corrosive gases.
2. Strictly follow the parameter as specified.
3. Installation procedure:
 - 3.1 Ensure the floor is level and of sufficient strength.
 - 3.2 The belt guard must be equipped with and have a minimum 30cm clearance.
 - 3.3 Check the belt tension and alignment properly.
 - 3.4 The location should be dry and free from dust, humidity and aggressive or explosive gas.
4. Use only OMC genuine parts for servicing and maintenance.
5. Warranties are excluded if not operated in the intended way and do not conform with the users' manual directives.



Date 2/26/2015	Part Number 230106	Description P3 OIL-LESS COMPRESSOR	Unit IN (mm)
-------------------	-----------------------	---------------------------------------	-----------------