



SELECTORR® Series Claw Vacuum Pumps  
C3B | C5B | C7LB | C7B | C10B | C15B Models

---

**Installation & Operation Manual**



---

# **INSTALLATION & OPERATING MANUAL**

## **SELECTORR® SERIES CLAW VACUUM PUMPS C3B, C5B, C7LB, C7B, C10B, C15B**

Please read the manual before operating the vacuum pump.

### **TABLE OF CONTENTS**

#### **1.0 INSTALLATION**

1.1	General Description	4
1.2	Unpacking	4
1.3	Location	4
1.4	Power Requirements	4
1.5	Pressure Connections	5
1.6	Oil Filling on Gear box	6

#### **2.0 SAFETY**

2.1	General Notices	7
2.2	Warning Labels and explanation	7
2.3	Location of Labels	8

#### **3.0 OPERATION**

3.1	Start-up	8
3.2	Stopping the Pump	8
3.3	Operating Conditions	8

#### **4.0 MAINTENANCE**

4.1	Pump Lube Oil (level, type, quantity, change)	9
4.2	Maintenance Chart	9

#### **5.0 PROBLEM SOLVING** 10

#### **6.0 TECHNICAL DATA** 12

#### **7.0 TYPICAL ASSEMBLY DRAWING AND PARTS LISTS** 13

---

## INSTALLATION AND OPERATING MANUAL

This manual covers contact-less operating claw type pumps. The model number is stamped into the nameplate with serial number: C3B, C5B, C7LB, C7B, C10B, C15B.

**Please identify the model number and serial number when ordering parts.**

### 1.0 INSTALLATION

#### 1.1 General Description

The SELECTORR pump is a dry and contactless machine, enclosed in an acoustic sound shield and designed to have cooling air passed through the sound shield by fan. The warm air is exhausted through the vent. The pump is constructed in modular construction consisting of two compartments: pumping and gear chambers separated by using labyrinth seals. In the pump chamber, as two rotary claws rotate in opposite directions, the air is sucked in, compressed and discharged under pressure. In the gear chamber (box), are two gears for synchronizing of claw rotation, providing oil lubrication. An anti-suck back valve can be installed in inlet flange and will prevent the air from back flowing into the vacuum chamber after the pump is shutdown. The pump is directly driven by a flanged motor via a coupling.

#### 1.2 Unpacking

Inspect the box and pump carefully for any signs of damage incurred in transit. Since all pumps are ordinarily shipped F.O.B. from our factory or regional warehouse, such damage is the normal responsibility of the carrier and should be reported to them. The pump is bolted to the skid with studs that are connected through the rubber feet of the pump. Remove the nuts from the underside of the crate and remove the pump. Unscrew the studs from the rubber feet. The inlet and exhaust of the pump are covered with plastic caps to prevent dirt and other foreign substances from entering. Leave these caps in place until you are ready to pipe the pump to your equipment.

#### 1.3 Location

Install the pump in a horizontal position on a level surface so that it can be evenly supported on its rubber feet. Leave 8" to 10" of access around the pump to allow proper cooling. Adequate ventilation must also be provided for the cooling of the pump and motor. Allow access to the oil sight glass in order to inspect the oil level regularly, and the oil fill and oil drain port for easy service.

#### 1.4 Power Requirements

A schematic diagram for the electrical motor terminal connections is located in the junction box of the motor or on the motor nameplate. Typical wirings for Three Phase Motors are shown on page 4:

---

## Wiring Scheme - Three Phase Motor

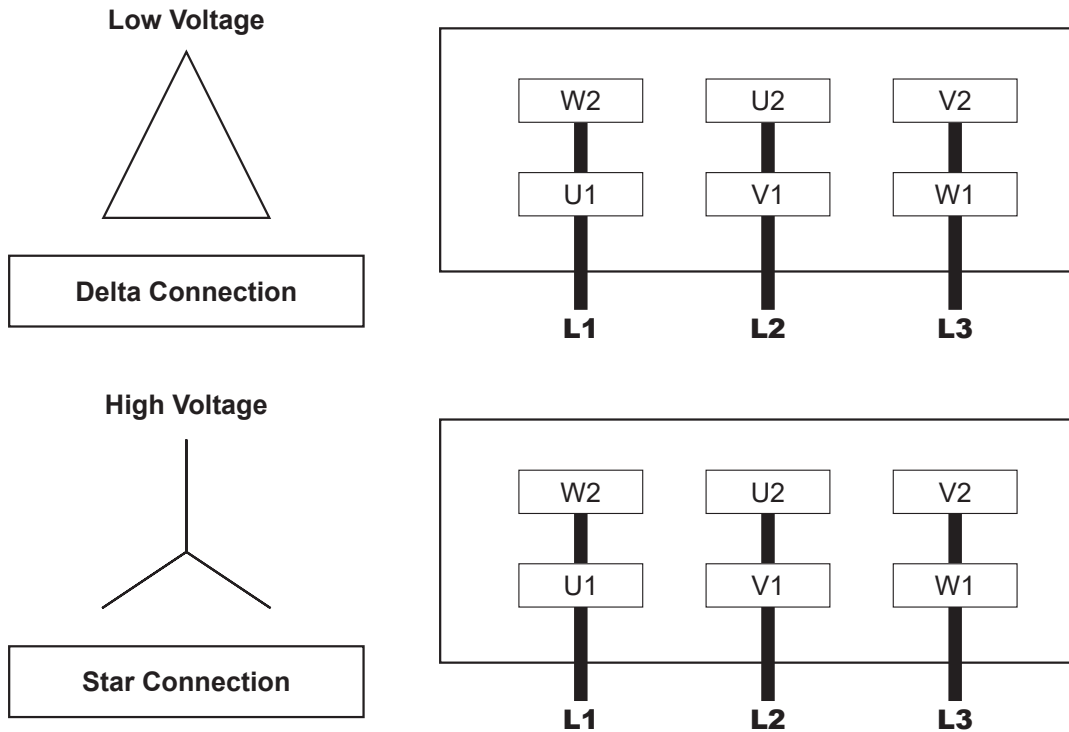

The motor must be connected according to the electrical codes through a fused switch in order to protect the motor against electrical or mechanical overload conditions. The overload of the motor starter must be set at a level equal to the full load motor current listed on the motor nameplate.

If the pump is supplied with a motor starter, it is preset at the factory according to customer specifications. It is advisable to check that these settings are in line with the voltage at your location. If the voltage is different, please contact Ohio Medical for motor and starter information.

Correct direction of rotation is marked by an arrow on the motor fan housing and is counterclockwise when looking at the motor from the motor's fan side.

*After electrical connections have been made, the rotation of the motor should be checked. If backward, reverse any two leads of the three at the power connection.*

### 1.5 Vacuum Connections

Use a pipe size that is at least the size of the pump outlet connection. Smaller and long pipe lines result in a reduced pump capacity.

Compressors operating in parallel on a common main line should have a manual or automatic operated shut-off valve, or a positive action check valve installed in the pressure line. Remove the plastic protective cap from the exhaust port prior to connecting the pump to the system.

Should process gas contain dust or other foreign particles, a suitable inline (inlet) filter should be connected to the inlet port. Consult Ohio Medical for recommendations.

The following thread sizes are standard on the pumps (NPT):

Pump Models	Inlet Size	Exhaust Size
C3B & C5B	1½"	1½"
C7LB & C7B	2"	2"
C10B & C15B	3"	3"

### 1.6 Oil Filling on Gear Box

The pump is shipped without oil in gear box. After level installation and correct rotation have been established, fill the pump with recommended gear oil through the oil fill port. Oil level should be over 3/4 position on the oil sight glass as shown on the label.



Contact Ohio Medical for all required oils and greases. We recommend ISO VG150 gear oil or equivalent oils.

The table gives the approximate quantities of oil required for each model.

Pump Model	Capacity (Quart)
C3B & C5B	0.50
C7LB & C7B	1.00
C10B & C15B	2.00

**Do not add oil with vacuum pump running! Do not overfill.**

## 2.0 SAFETY

Please read the following safety notice carefully before operating the pump.

### 2.1 General Notices

- Understand fully this installation and operating manual before operation.
- Only an authorized operator should operate the vacuum pump.
- When the pump is not properly working, it should be stopped immediately.
- Ohio Medical shall have no liability for any accident and failure arising from non-compliance with instructions in this manual.

### 2.2 Warning Labels and Explanations

The following warning labels are shown and attached on the Claw vacuum pumps.

#### 2.2.1 Read and Understand the Manual

Read and understand operator's manual before using this machine.

#### 2.2.2 Burn Hazard

Hot surface. Do not touch.

---

### 2.2.3 Loud Noise Hazard

Loud noise hazard. Ear protection must be worn.

### 2.2.4 Hazardous Voltage

Disconnect power before opening. Contact causes severe electrical shock.

## 2.3 Location of the Labels

The labels of 2.2.1 Read and Understand the Manual, 2.2.2 Burn Hazard, and 2.2.3 Loud Noise Hazard shall be shown on the top of the sound shield of the pump.

The label of 2.2.4 Hazardous Voltage shall be shown on the cover of the motor's terminal box.

## 3.0 OPERATION

### 3.1 Start-up

Check rotation of the motor as described in paragraph 1.4 Power Requirements. Fill the pump with oil as described in paragraph 1.6 - Oil Filling.

Run the pump for a few minutes and then shut down. Check the oil level again and make sure the oil level is 1/2 position of oil sight glass at stop status.

Add oil through oil fill port on the top. Pump oil should only be added when the pump is off.

### 3.2 Stopping the Pump

To stop the pump, turn off the power. A check valve is installed in the inlet flange that will prevent the air from back flowing into the vacuum receiver after the pump is shutdown.

**Caution: In applications, where the quantity of water vapor is moderate, it is recommended to run the pump for 10 minutes at least with outside air prior to shut down to prevent the vapor from condensing in the pump.**

### 3.3 Operating Conditions

The C3B, C5B, C7LB, C7B, C10B, C15B are designed to run the ultimate vacuum levels stated in technical data (6.0) for continuous operation. Operation over maximum vacuum level may result in failure of and severe damage to the machine.

Vacuum Regulator installed in inlet flange is set at maximum allowable vacuum at factory, and a desired vacuum level to below the maximum level can be achieved by rotating the adjustment knob.

The standard version is for use of dry air only, and may not be used in hazardous areas. Handling of humid air or gases containing aggressive chemicals is possible only with specially configured units. Consult Ohio Medical for assistance.

Excessive back pressure on the unit may result in excessive current draw. Do not operate the vacuum pump over 2 psi back pressure.

Ear protection is recommended for operating personnel who are working near the pump. If noise below the designed dBA is required, an external sound enclosure can be added to the system, provided adequate ventilation is provided.

The ambient and suction air temperature must be between 40°F and 104°F.

**Caution: Any non compliance may lead to severe injury to persons and damage to the pump.**

**Caution: Maximum number of motor starts per hour should not exceed 10 per hour. Excessive starting of the motor can cause overheating and premature failure of the motor. A minimum run timer should be used with any panel that may control the pump with automatic starts and stops based on system pressures.**

## 4.0 MAINTENANCE

SELECTORR® series vacuum pumps require very little maintenance. To ensure optimum performance, the following maintenance steps should be followed:

### 4.1 Gear Box Oil

#### 4.1.1 Gear Box Oil Level

Check the oil level on a monthly basis. Under normal circumstances, it should not be necessary to add oil between oil changes. A significant drop in oil level means there is an oil leak. Please check the O-rings, drain plug or oil sight glass.

Check the oil level only when the pump is shut off. Replenish oil if it drops below bottom position of the sight glass.

#### 4.1.2 Gear Box Oil Type and Quantity

See section 1.6 - Oil Filling - for details on oil type and capacity.

#### 4.1.3 Gear Box Oil Change

Under normal ambient conditions with proper Gear Oil, it is recommended to change the oil every 3000 operation hours.

### 4.2 Maintenance Chart

<b>Weekly</b>	Check inline inlet filter element / mesh. More often if high particulates in inlet stream.
<b>Monthly</b>	Check the oil level, protective mesh.
<b>Semi-Annually</b>	Check fans and coupling.
<b>Annually</b>	Check bearings / shaft seals. More frequently if operated at ambient temperature exceeding 68°F.
<b>Every 3000 Operating Hours</b>	Change the gear oil

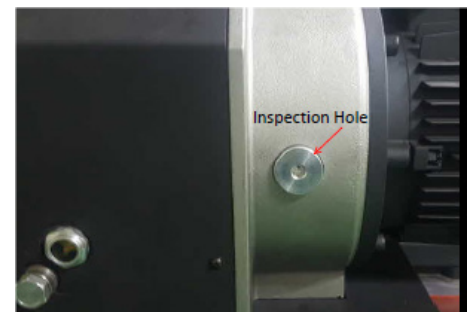

Inspection hole with G1" plug: Check the coupling and its insert, and fan through this hole regularly.

---

## 5.0 PROBLEM SOLVING

5.1 Problem: The pump does not reach capacity.

5.1.1 Possible Cause: Inlet screen (mesh) of the inlet filter clogged with debris.

**Remedy:** check inlet filter element and clean screen (mesh) by compressed air or wash it.

5.1.2 Possible Cause: Pipe work is too long or small.

**Remedy:** Use a bigger diameter pipe and shorten the lines length if possible.

5.2 Problem: The pump runs over set pressure.

5.2.1 Possible Cause: Inlet screen (mesh) in the vacuum regulator clogged with debris.

**Remedy:** Clean screen (mesh) and check inlet filter element.

5.2.2 Possible Cause: Vacuum regulator set over the set point or is out of order.

**Remedy:** Set the point again or replace it with new one.

5.3 Problem: Vacuum pump does not reach the set pressure.

5.3.1 Possible Cause: Leak on the pump or system.

**Remedy:** Check the leak on the pump or system.

5.4 Problem: The pump is extremely noisy.

5.4.1 Possible Cause: Contamination of the claws or chamber.

**Remedy:** Clean the pumping chamber and the claws.

5.4.2 Possible Cause: Coupling insert is worn.

**Remedy:** Replace coupling insert in motor/pump coupling.

5.4.3 Possible Cause: Bearing noise.

**Remedy:** Replace bearings or call service agent for service or exchange program.

5.4.4 Possible Cause: Vacuum regulator noise.

**Remedy:** Replace vacuum regulator.

5.5 Problem: The pump will not start.

5.5.1 Possible Cause: Supply voltage is not proper or is overloaded. Motor starter overload settings are too low or improper; fuses are burned; wire size is too small or too long causing a voltage drop.

**Remedy:** Check voltage supply; overload settings in motor starter for size and settings according to motor nameplate. Install proper size wire. If ambient temperature is high, use the next larger size overloads, or adjust settings 5% above motor nameplate value.

**Remedy:** Repair or replace if needed or call service agent for service or exchange program.



**Remedy:** Turn pump by hand. If it will not turn, remove motor from pump and check motor and pump separately. Repair or replace if needed or call service agent for service or exchange program.

5.6 Problem: The pump is running abnormally hot.

5.6.1 Possible Cause: Not enough air ventilation to pump.

**Remedy:** Make certain a sufficient amount of fresh air is supplied to the pump. Check for dirty or blocked mesh, clean mesh as necessary.

5.7 Problem: The pump will not operate (seized up).

5.7.1 Possible Cause: Rotary claws, bearings or gears stuck on.

**Remedy:** Call service agent for service or exchange program.

## 6.0 TECHNICAL DATA

VACUUM APPLICATION SPECIFICATIONS							
Model		C3B	C5B	C7LB	C7B	C10B	C15B
ACFM	60 HZ	70	112	165	212	275	350
	50 HZ	58	93	137	176	228	291
Continuous Vacuum	inHg	25"	25"	24"	24"	24"	24"
Motor HP	60 Hz	3	5	7.5	7.5	10	15
	50 HZ	2.5	4.2	5.8	7.4	10	12
Motor RPM	60 Hz	3450/2850	3450/2850	3450/2850	3450/2850	3450/2850	3450/2850
	50 HZ						
Voltage Available		220-240/380-420V x 50/60Hz, 208-230/460V x 60Hz	220-240/380-420V x 50/60Hz, 208-230/460V x 60Hz	208-230/460V, 220-240 / 380-420V, 400/690V	208-230/460V, 220-240 / 380-420V, 400/690V	208-230/460V, 220-240 / 380-420V, 400/690V	208-230/460V, 220-240 / 380-420V, 400/690V
dB(A)	60Hz	75	77	80	80	78	80
	50 HZ	72	73	78	78	76	78
Oil Capacity (Gear Box)	Quarts (QT)	0.50	0.50	1.00	1.00	2.00	2.00
Inlet/Outlet Connections	NPT	1½"	1½"	2"	2"	3"	3"
L * W × H (inches)	60Hz	33" × 17.1" × 22.1"	34" × 17.1" × 22.1"	37.8" × 19.7" × 27"	38.4" × 19.7" × 27"	43.5" × 23" × 27.4"	50.8" × 23" × 27.4"
	50 HZ	33" × 17.1" × 22.1"	34" × 17.1" × 22.1"	37.8" × 19.7" × 27"	38.4" × 19.7" × 27"	42" × 23" × 27.4"	44" × 23" × 27.4"
Operating Temperature	Fahrenheit	40 ~ 104°F					
Approximate Weight* (without motor)	Pounds (lbs)	280	302	514	548	741	750
Accessories	Non Return Valve, Vacuum Regulator, Exhaust Silencer						

\*length varies to motor

# C3B CLAW VACUUM PUMP WITH 3 HP NEMA 182TC MOTOR

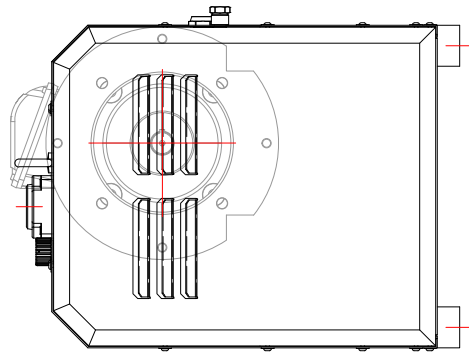
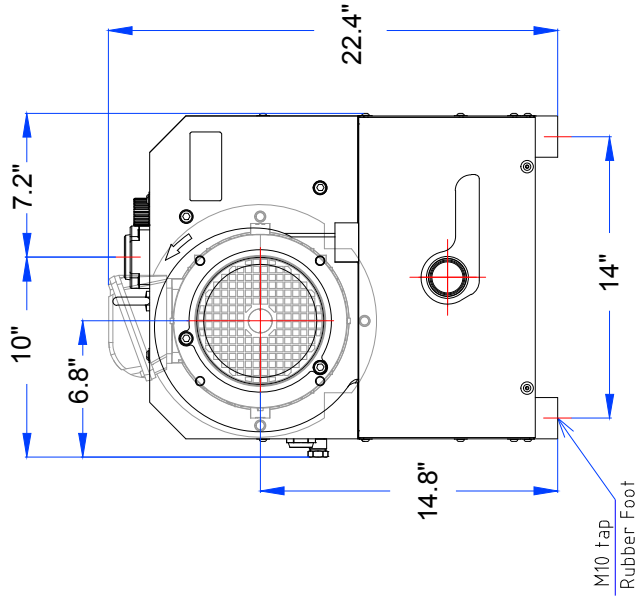
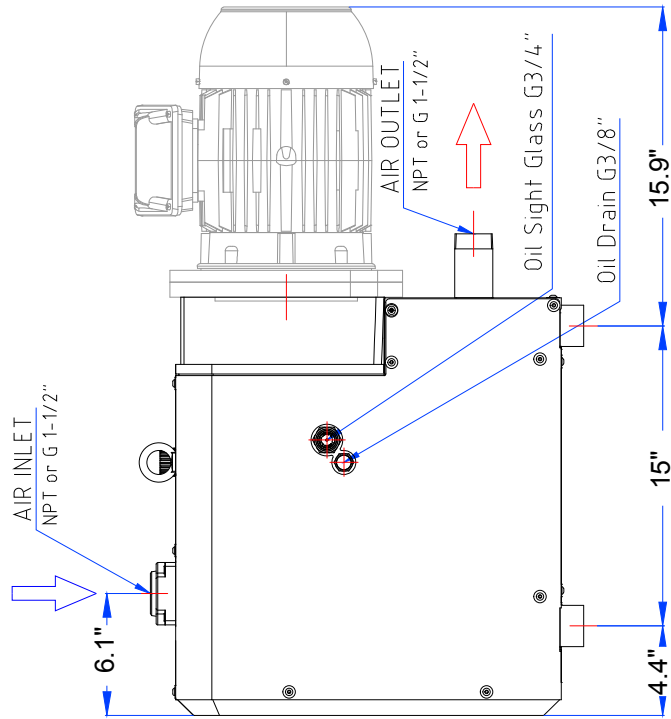
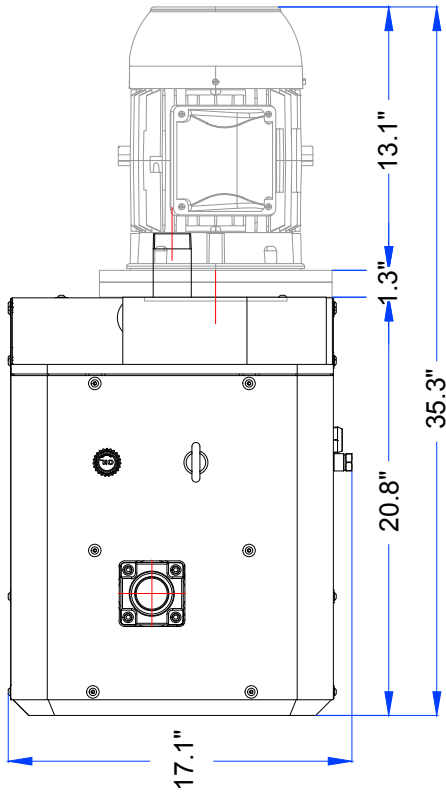
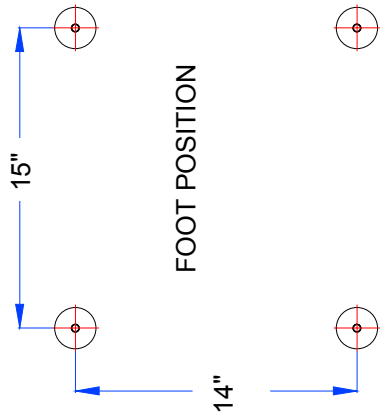

# C5B CLAW VACUUM PUMP WITH 5 HP 184TC NEMA MOTOR

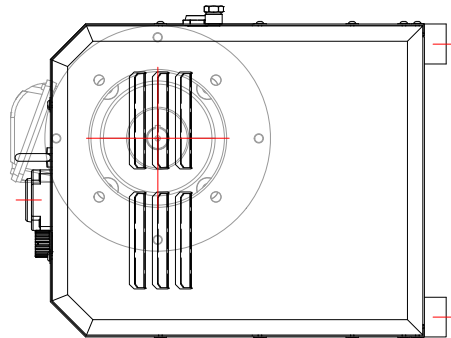
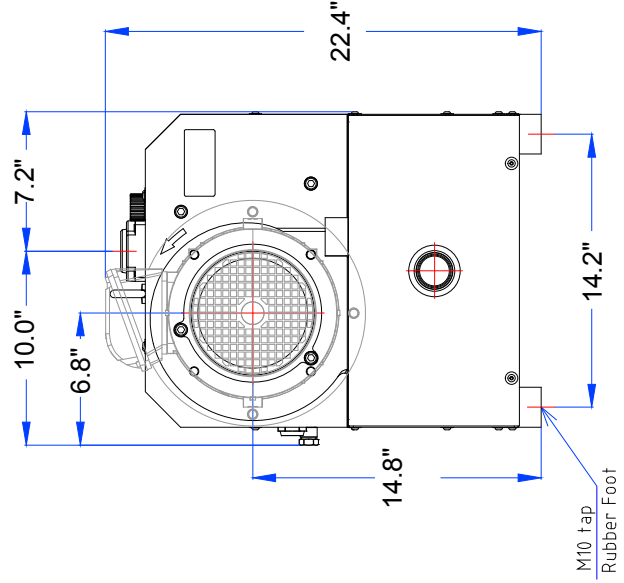
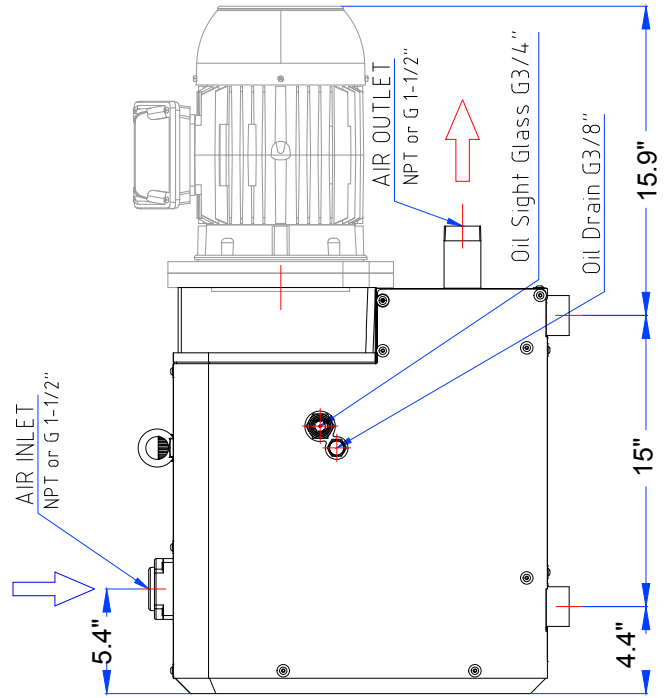
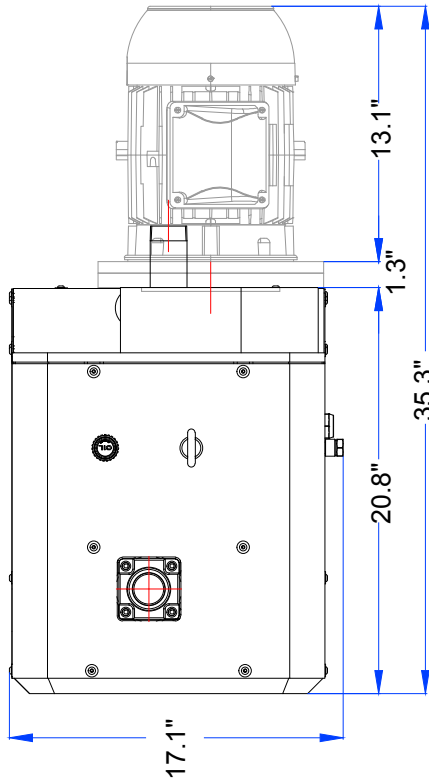
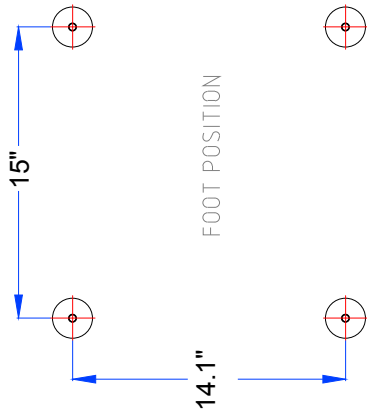

# C7B CLAW VACUUM PUMP WITH 7.5 HP NEMA 182TC MOTOR

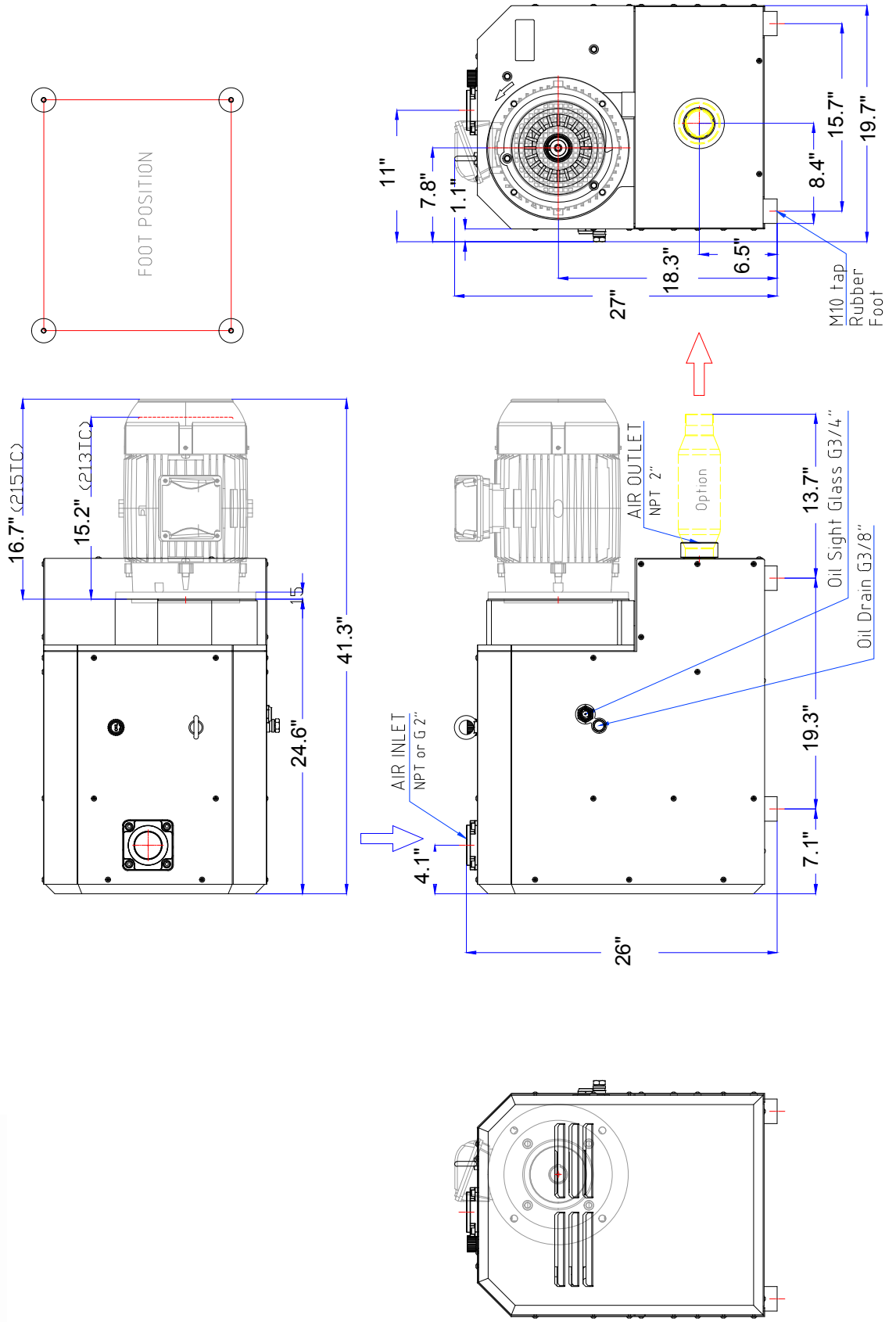

# C7LB CLAW VACUUM PUMP WITH 7.5 HP NEMA 213TC MOTOR

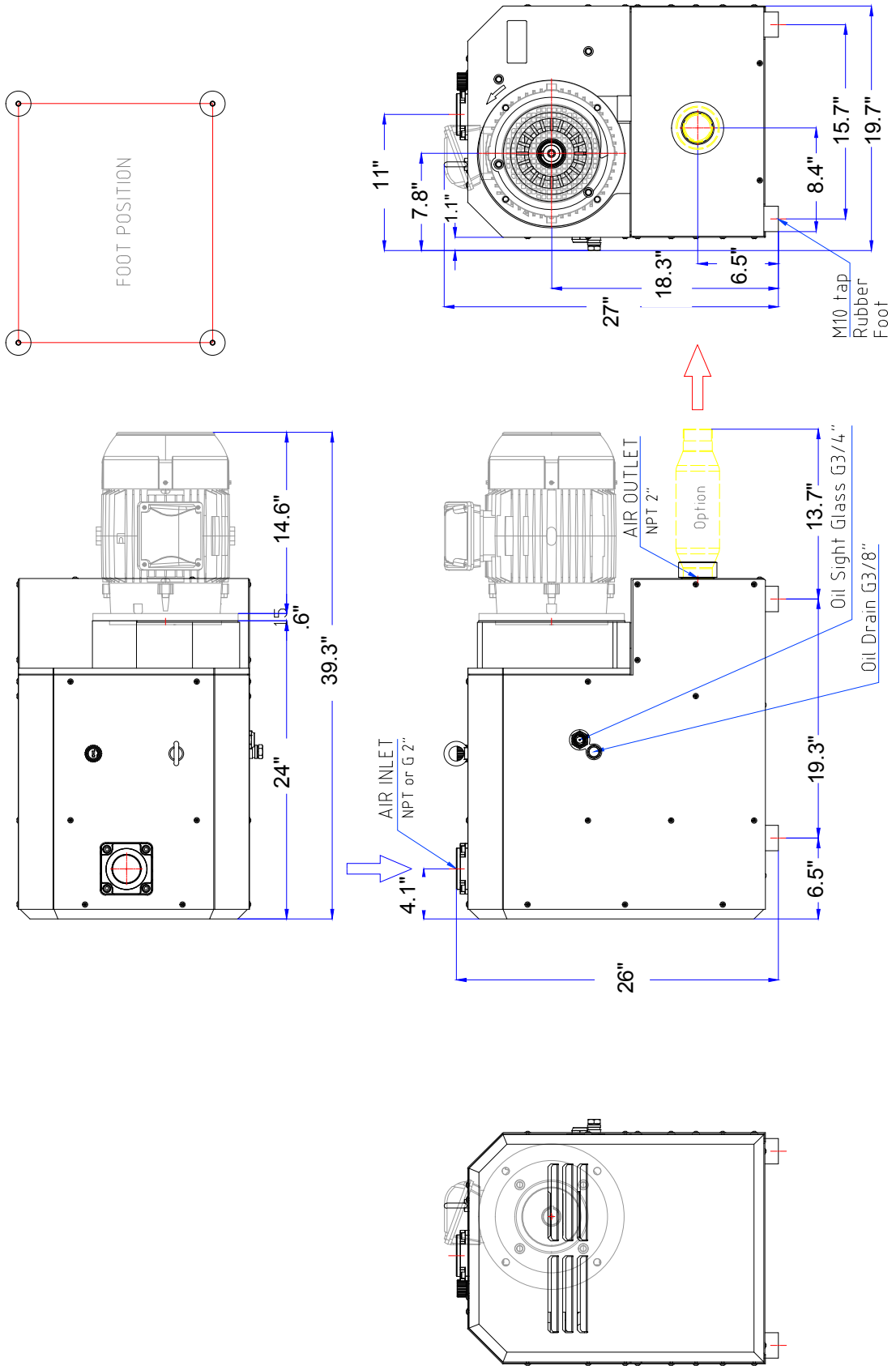

# C10B CLAW VACUUM PUMP WITH 15 HP NEMA 254TC MOTOR

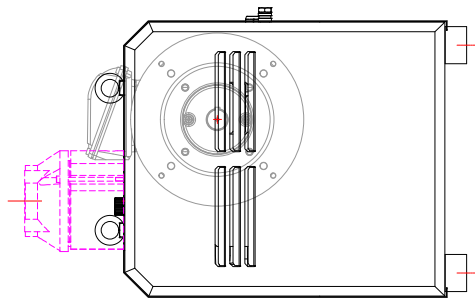
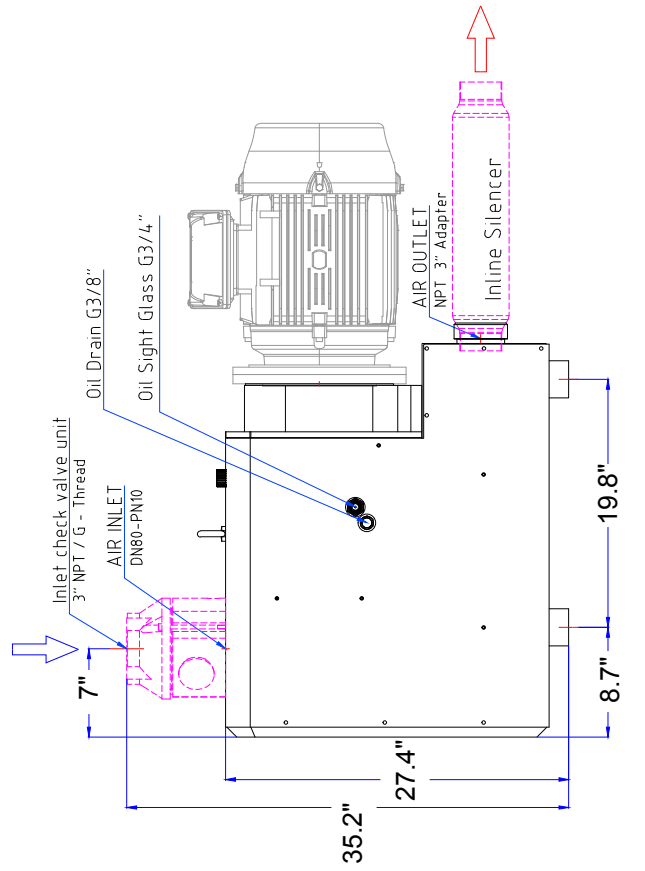
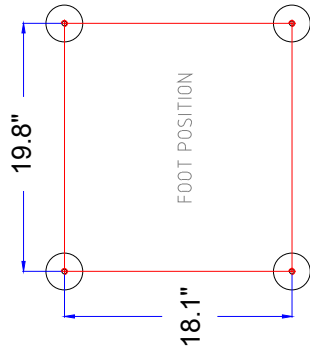
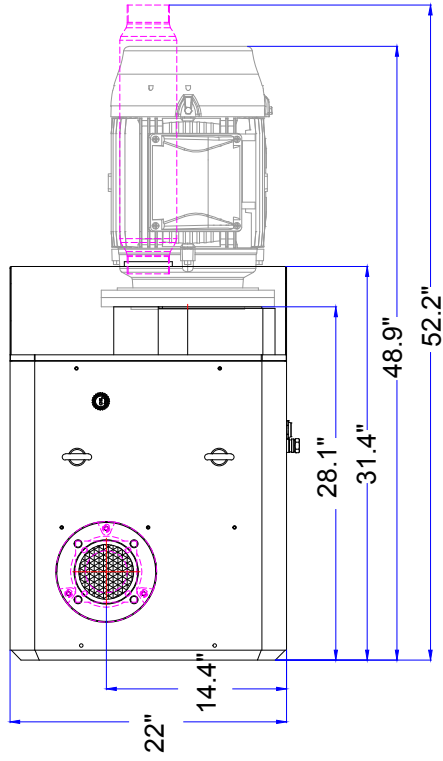

# C10B CLAW VACUUM PUMP WITH 10 HP NEMA 215TC MOTOR

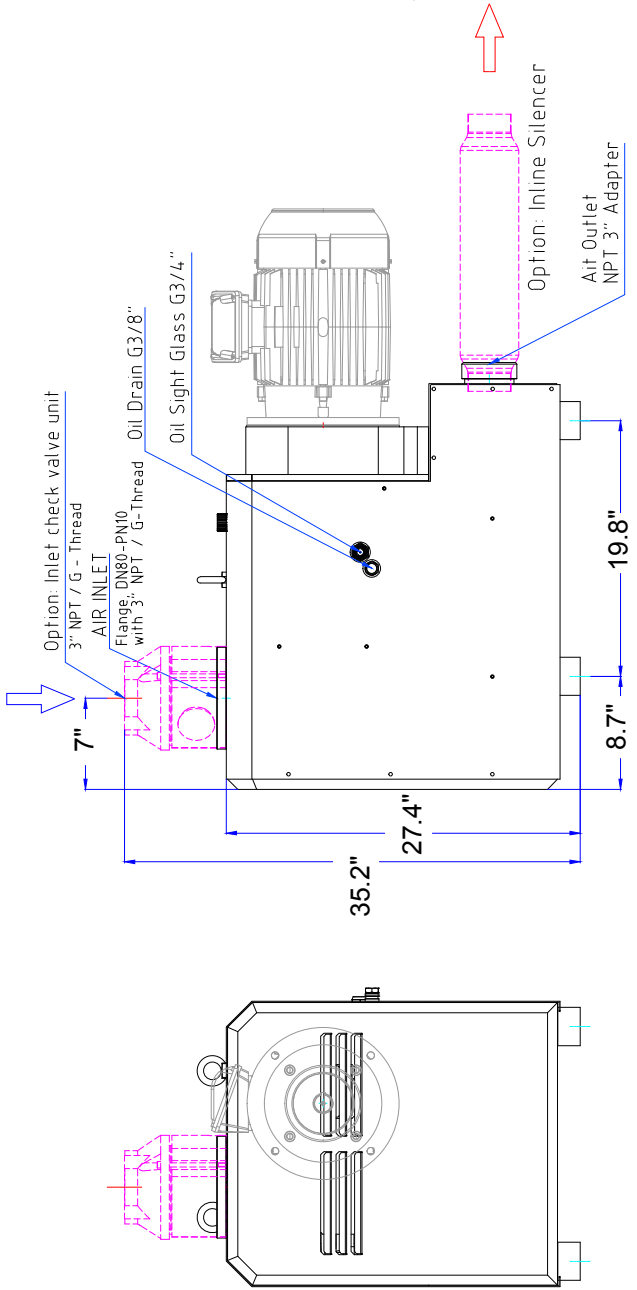
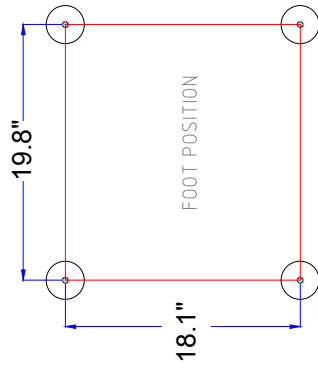
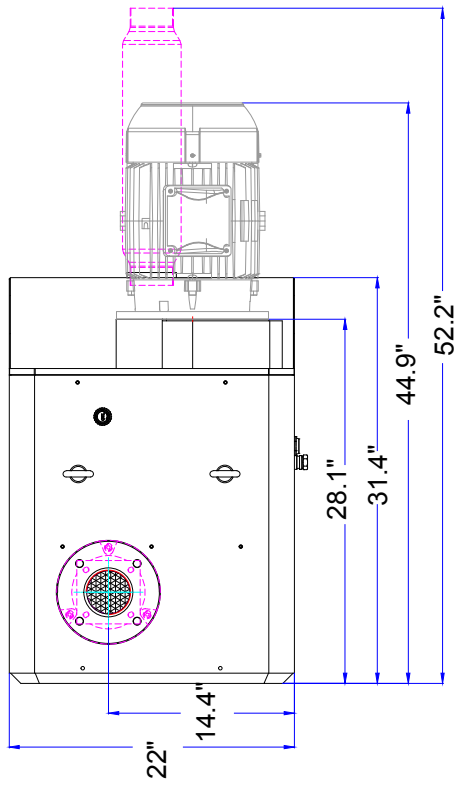

# C15B CLAW VACUUM PUMP WITH 15 HP NEMA 254TC MOTOR

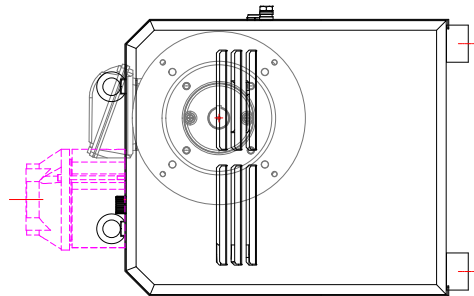
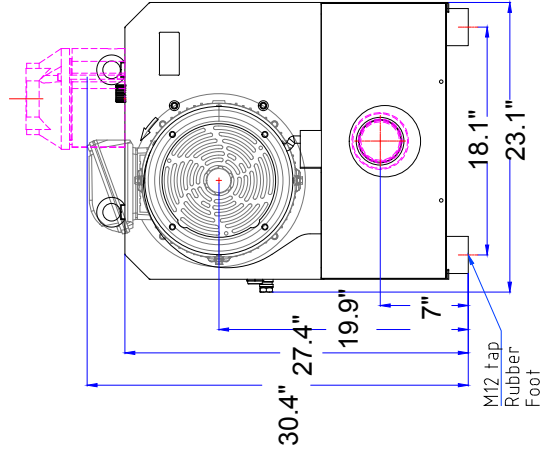
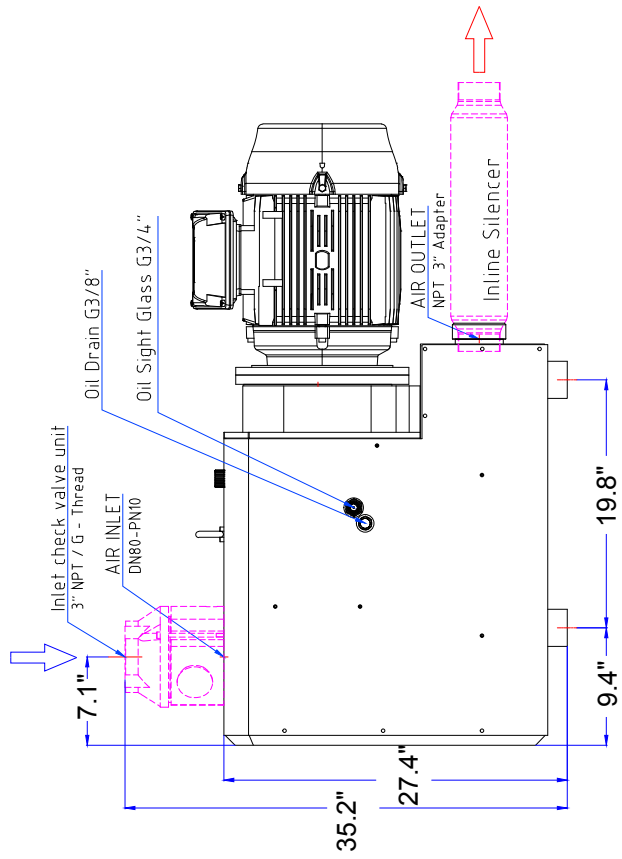
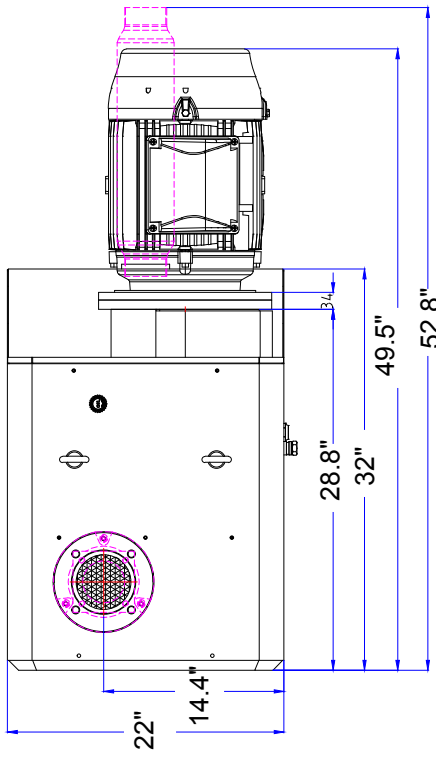
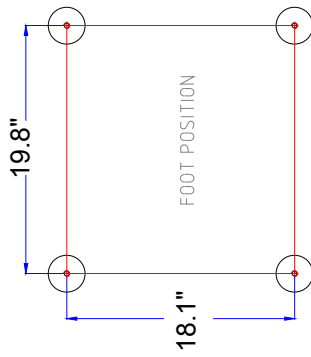



# ASSEMBLY DRAWING C3B/C5B

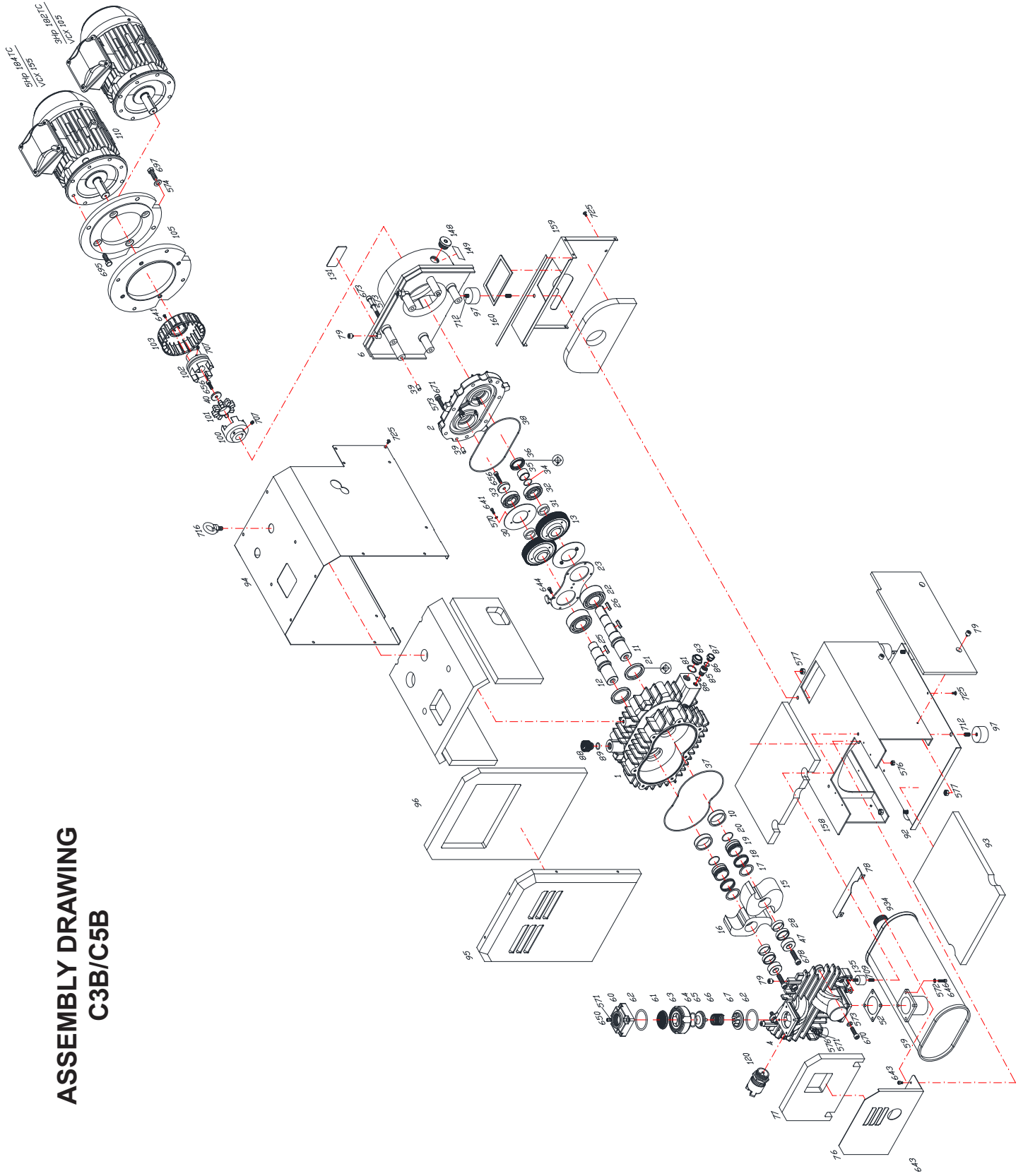

## C3B/C5B PART LIST

POS #	Description	Qty							
1	Gear Box Housing	1	60	Inlet flange, Upper Housing	1	149	Label, Inspection hole	1	
2	Gear Box Cover (rear)	1	61	Inlet screen (Conical)	1	158	Base	1	
4	Pump Housing Cover 1 (End Plate)	1	62	O-Ring, Inlet Flange, low and upper part	2	159	Cover, Exhaust	1	
6	Fan Housing	1	63	Inlet Flange, Lower Housing	1	160	Seal	1	
10	Sleeve	2	64	O-Ring, Check Valve Plate	1	570	Washer, Spring Lock, 5mm	4	
11	Shaft 1	1	65	Check Valve Plate	1	571	Washer, Spring Lock, 8mm	6	
12	Shaft 2	1	66	Spring, Check Valve	1	573	Washer, Spring Lock, 10mm	18	
13	Gear 1	2	67	Check Valve Guide	1	574	Washer, Spring Lock, 12mm	4	
15	Rotor 1	1	76	Plate (vertical)	1	576	Hexagon Nut M8	4	
16	Rotor 2	1	77	Acoustic mat	1	577	Hexagon Nut M10	5	
17	Spacer	2	78	Plate (horizontal)	1	641	Hex. Socket Head Cap Screw / M5 x 15	9	
18	Piston Ring	4	79	Support isolator	8	643	Hex. Socket Head Cap Screw / M6 x 10	4	
19	Sleeve	2	81	Gasket, Oil Sight Glass	1	644	Hex. Socket Head Cap Screw / M6 x 15	8	
20	O-Ring	2	83	Oil Sight Glass	1	646	Hex. Socket Head Cap Screw / M8 x 25	4	
21	Shaft Seal,	2	85	Pipe, for Drain Plug	1	650	Hex. Socket Head Cap Screw / M6 x 65	4	
22	Bearing,	2	86	O-ring, Drain Plug	2	656	Hex. Socket Head Cap Screw / M8 x 25	2	
23	Bearing cover	1	87	Drain Plug	1	670	Hex. Socket Head Cap Screw / M10 x 35	7	
25	Key, for Gear 8x7x30	2	88	Oil filler Breather, Plastic	1	671	Hex. Socket Head Cap Screw / M10 x 50	7	
26	Key, for Coupling 8x7x30	1	89	O-Ring for Oil filler	1	673	Hex. Socket Head Cap Screw / M10 x 85	4	
28	Power Lock	2	92	Shield Cover, Bottom	1	678	Hex. Socket Head Cap Screw / M12 x 45	2	
30	Flinger	2	93	Acoustic Mat for Shield Cover, Bottom	1	695	Hexagon Bolt / M12 x 25	4	
31	Sleeve	2	94	Shield Cover, Side	1	697	Hexagon Bolt / M12 x 35	4	
32	Bearing,	2	95	Shield Cover, Front	1	707	Set Screw / M8 x 15	4	
33	Locking Disk, Shaft 2	1	96	Acoustic Mat for Shield Cover, front and Side	1	709	Set Screw / M8 x 20	4	
34	O-Ring	1	97	Foot, Rubber, 52x30xM10	5	712	Set Screw / M10 x 25	6	
35	Sleeve	1	100	Coupling, Pump Side	1	716	Eye Bolt M12	1	
36	Shaft Seal,	1	101	Insert, Coupling	1	725	Round Head Bolt / M5 x 10	26	
37	O-Ring, Compressor Cover	1	102	Coupling, Motor Side	1				
38	O-Ring, Gear Box Cover	1	103	Fan, new, Plastic	1				
39	Dowel Pin	4	105	Flange Adapter (IEC 132, NEMA only)	1				
40	Locking Disk, Shaft 1	1	110	Motor	1				
47	Locking Disk, side Rotor	2	120	Vacuum Regulator	1				
52	Gasket, Exhaust Silencer	1	130	Label, Direction Arrow	1				
47	Locking Disk, side Rotor	2	131	Name Plate	1				
52	Gasket, Exhaust Silencer, Steel Silencer	1	135	Foot, Rubber, 30x20xM8	2				
59	Silencer Assembly	1	148	Plug G-1", Inspection Hole	1				

**ASSEMBLY DRAWING  
C7LB/C7B**

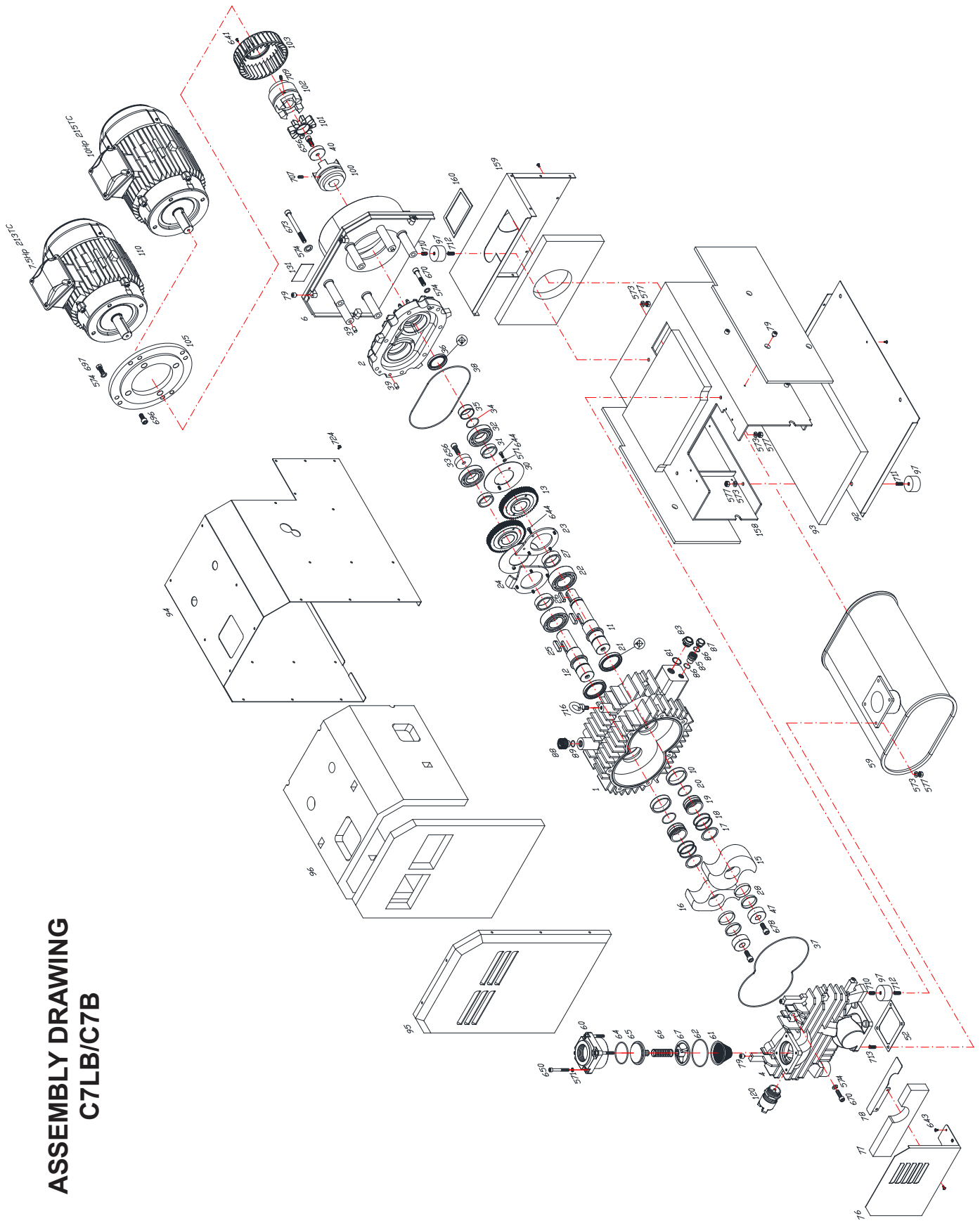

## C7LB/C7B PART LIST

POS #	Description	Qty						
1	Gear Box Housing	1	60	Inlet flange, Upper Housing, G 2"	1	160	Seal	1
2	Gear Box Cover (rear)	1	61	Inlet screen (Conical )	1	571	Washer, Spring Lock, 6mm	8
4	Pump Housing Cover 1 (End Plate)	1	62	O-Ring, Inlet Flange, upper part	1	573	Washer, Spring Lock, 10mm	11
6	Fan Housing	1	64	O-Ring, Check Valve Plate	1	574	Washer, Spring Lock, 12mm	22
10	Sleeve	2	65	Check Valve Plate	1	577	Hexagon Nut M10	11
11	Shaft 1	1	66	Spring, Check Valve	1	641	Hex. Socket Head Cap Screw / M5 x 15	5
12	Shaft 2	1	67	Check Valve Guide	1	643	Hex. Socket Head Cap Screw / M6 x 10	4
13	Gear 1	2	76	Plate (vertical)	1	644	Hex. Socket Head Cap Screw / M6 x 15	12
15	Rotor 1	1	77	Acoustic Mat	1	650	Hex. Socket Head Cap Screw / M6 x 65	4
16	Rotor 2	1	78	Plate (horizontal)	1	656	Hex. Socket Head Cap Screw / M12 x 25	2
17	Spacer	2	79	Support Isolator	14	670	Hex. Socket Head Cap Screw / M12 x 50	14
18	Piston Ring	4	81	Gasket, Oil Sight Glass	1	673	Hex. Socket Head Cap Screw / M12 x 110	4
19	Sleeve	2	83	Oil Sight Glass	1	678	Hex. Socket Head Cap Screw / M12 x 25	2
20	O-Ring	2	85	Pipe, for Drain Plug	1	695	Hexagon Bolt / M12 x 25 (IEC 112M, NEMA 213TC, 215TC)	4
21	Shaft Seal,	2	86	O-ring, Drain Plug	2	696	Hexagon Bolt (NEMA only)	4
22	Bearing,	2	87	Drain Plug	1	697	Hexagon Bolt / M12 x 35	4
23	Bearing cover (Plate)	1	88	Oil filler Breather, Plastic	1	707	Set Screw / M8 x 15	2
24	Bearing cover	1	89	O-Ring for Oil filler	1	709	Set Screw / M8 x 10	2
25	Key, for Gear	2	92	Shield Cover, Bottom	1	710	Set Screw / M10 x 15	3
26	Key, for Coupling	1	93	Acoustic Mat for Shield Cover, Bottom	1	711	Set Screw / M10 x 20	4
27	Sleeve	2	94	Shield Cover, Side	1	712	Set Screw / M10 x 25	3
28	Power Lock (VCX-305)	2 (4)	95	Shield Cover, Front	1	713	Set Screw / M10 x 35	4
30	Flinger	2	96	Acoustic Mat for Shield Cover, front and Side	1	716	Eye Bolt M12	1
31	Sleeve	2	97	Foot, Rubber	7	724	Bottom Flange Bolt M5 x 8	44
32	Bearing,	2	100	Coupling, Pump Side	1			
33	Locking Disk	1	101	Insert, Coupling	1			
34	O-Ring	1	102	Coupling, Motor Side	1			
35	Sleeve	1	103	Fan, new, Plastic	1			
36	Shaft Seal,	1	105	Flange Adapter (IEC 112M, NEMA 213TC, 215TC)	1			
37	O-Ring, Compressor Cover	1	110	Motor	1			
38	O-Ring, Gear Box Cover	1	120	Vacuum Regulator	1			
39	Dowel Pin	4	130	Label, Direction Arrow	1			
40	Locking Disk	1	131	Name Plate	1			
47	Locking Disk, side Rotor	2	158	Base	1			
52	Gasket, Exhaust Silencer, Steel Silencer	1	159	Cover, Exhaust	1			
59	Silencer assembly steel	1						

**ASSEMBLY DRAWING**  
**C10B/C15B**

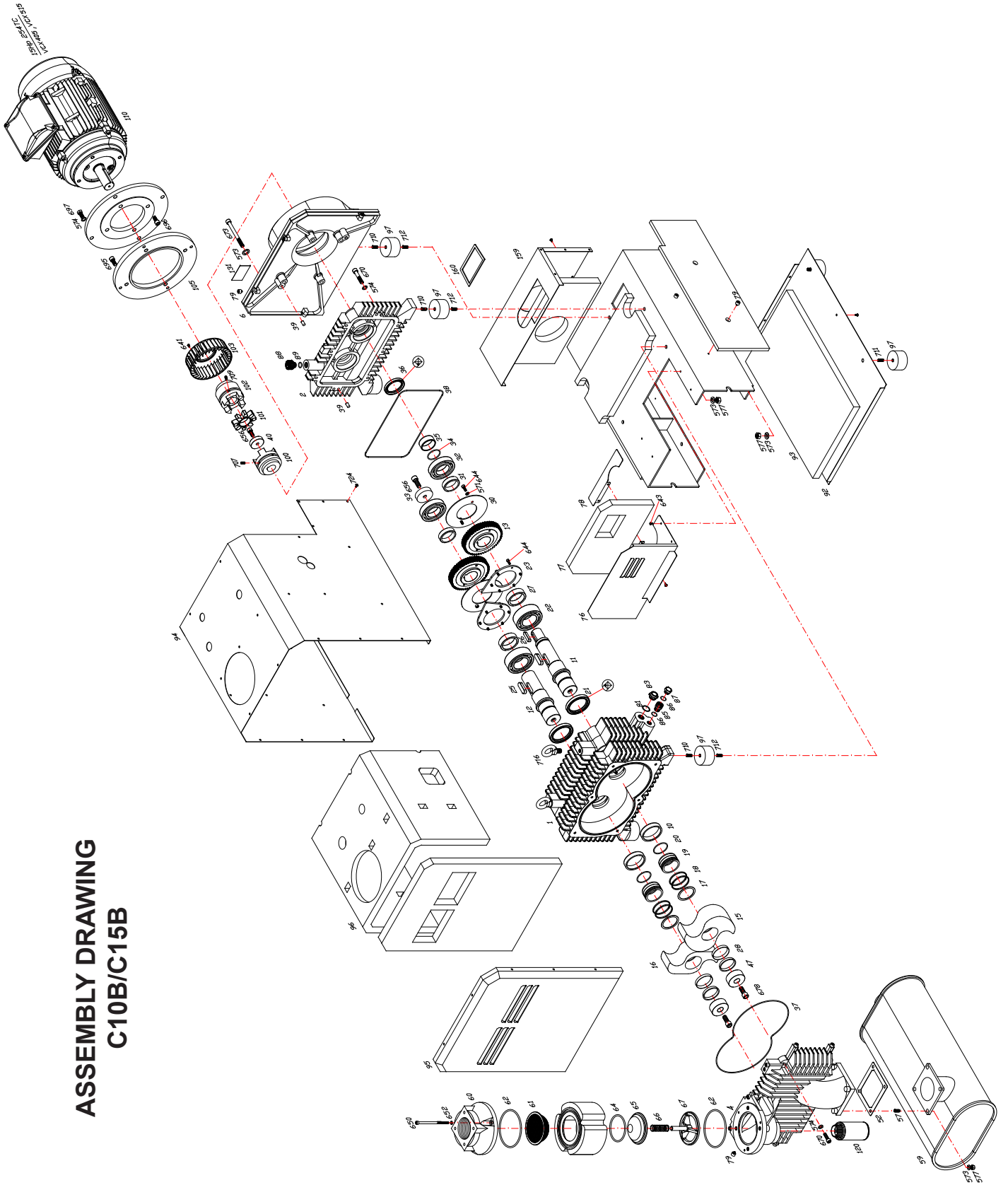

## C10B/C15B PART LIST

POS #	Description	Qty						
1	Gear Box Housing	1	60	Inlet Flang	1	571	Washer, Spring Lock, 6mm	16
2	Gear Box Cover (rear)	1	61	Inlet screen (Conical )	1	573	Washer, Spring Lock, 12mm	17
4	Pump Housing Cover (End Plate)	1	62	O-Ring, Inlet Flange	2	574	Washer, Spring Lock, 10mm	14
6	Fan Housing	1	64	O-Ring, Check Valve Plate	1	577	Hexagon Nut M12	13
10	Sleeve	2	65	Check Valve Plate	1	641	Hex. Socket Head Cap Screw / M5	5
11	Shaft 1	1	66	Spring, Check valve	1	643	Hex. Socket Head Cap Screw / M5	4
12	Shaft 2	1	67	Check Valve Guide	1	644	Hex. Socket Head Cap Screw / M6	16
13	Gear	2	76	Plate (vertical)	1	650	Hex. Socket Head Cap Screw / M8	3
15	Rotor 1	1	77	Acoustic Mat	1	652	Washer, Spring Lock, 8mm	3
16	Rotor 2	1	78	Plate (horizontal)	1	656	Hex. Socket Head Cap Screw / M12	2
17	Spacer	2	79	Support isolator	15	670	Hex. Socket Head Cap Screw / M10	14
18	Piston Ring	4	81	Gasket, Oil Sight Glass	1	673	Hex. Socket Head Cap Screw / M12	4
19	Sleeve	2	83	Oil Sight Glass	1	678	Hex. Socket Head Cap Screw / M16	2
20	O-Ring	2	85	Pipe, for Drain Plug	1	695	Hexagon Bolt / M12	4
21	Shaft Seal	2	86	O-ring, Drain Plug	2	696	Hexagon Bolt (NEMA only)	4
22	Bearing,	2	87	Drain Plug	1	697	Hexagon Bolt / M12	4
23	Bearing cover	2	88	Oil filler Breather, Plastic	1	707	Set Screw / M8	2
25	Key, for Gear	2	89	O-Ring for Oil filler	1	709	Set Screw / M8	2
26	Key, for Coupling	1	92	Shield Cover, Bottom	1	710	Set Screw / M12	5
27	Sleeve	2	93	Acoustic Mat for Shield Cover, Bottom	1	711	Set Screw / M12	4
28	Power Lock (VCX-515)	2(4)	94	Shield Cover, Side	1	712	Set Screw / M12	5
30	Flinger	2	95	Shield Cover, Front	1	716	Eye Bolt M16	2
31	Sleeve,	2	96	Acoustic Mat for Shield Cover, front and Side	1	724	Bottom Flange Bolt M5	37
32	Bearing	2	97	Foot, Rubber	9			
33	Locking Disk	1	100	Coupling, Pump Side	1			
34	O-Ring	1	101	Insert, Coupling	1			
35	Sleeve,	1	102	Coupling, Motor Side	1			
36	Shaft Seal	1	103	Fan, new, Plastic	1			
37	O-Ring, Compressor Cover	1	105	Flange Adapter	1			
38	O-Ring, Gear Box Cover	1	110	Motor	1			
39	Dowel Pin	4	120	Vacuum Regulator	1			
40	Locking Disk	1	130	Label, Direction Arrow	1			
47	Locking Disk, Front	2	131	Name Plate	1			
52	Gasket, Exhaust	1	158	Base	1			
57	Stud Bolt	4	159	Cover, Exhaust	1			
59	Silencer assembly steel	1	160	Seal	1			



**North America  
United States**

**Customer Service, Distribution Center  
Technical Support, Sales and Service  
Equipment Service Center**

Ohio Medical LLC  
1111 Lakeside Drive  
Gurnee, IL 60031 USA  
P: +1 866 549 6446  
F: +1 847 855 6218  
[www.ohiomedical.com](http://www.ohiomedical.com)

Maintenance parts for your claw vacuum pump are listed at:  
<https://www.ohiomedicalparts.com/products/rotary-claw-vacuum-pumps-oil-less.php>

© 2019 Ohio Medical LLC. This document contains information that is proprietary and confidential to Ohio Medical LLC. Use of this information is under license from Ohio Medical LLC. Any use other than that authorized by Ohio Medical LLC is prohibited. Ohio Medical, the Ohio Medical logo, are registered trademarks of Ohio Medical LLC.