

# SC1000-S2-V120 Claw Medical Vacuum System

System is NFPA compliant and has modular construction and interconnecting piping.

## PUMP MODULE

Oil-less rotary claw air cooled vacuum pump with NEMA motor. Each pump module is equipped with an inlet filter, check valve, pump isolation valve, internal discharge silencer, and temperature switch.

## SYSTEM CONTROLS

The UL listed soft start electrical control panel features a high-definition color touch screen that can be set up externally without the use of toggle switches. The panel displays multiple conditions, including pump running status, elapsed hours, vacuum level, and audio/visual alarms.

Standard features include lag alarm, automatic pump alternation, adjustable minimum run timer, adjustable vacuum settings, adjustable screen brightness, alarm history registry, and data logging. The panel has standard dry contacts and Modbus interface with building management systems. Ethernet and BACnet are available as options. The panel's maintenance menu includes service items and maintenance warnings, and it is programmed for both English and Spanish languages.

## VACUUM RECEIVER

Constructed to ASME standards and rated for full vacuum. Equipped with valved bypass, high visibility vacuum gauge, source isolation valve, and a manual drain valve. Mounting pads and flex connectors supplied for field installation.

## KEY OPTIONS

Variable Speed Drive Electrical Panel  
 O2 Assured Oil for gearbox  
 Configurable for Lab or Industrial Applications  
 Gas Purge System for Lab use

<b>Configuration</b>	Duplex Stack Mount
<b>System Capacity*</b>	75 SCFM @ 19" Hg. 60 Hz. 62.5 SCFM @ 19" Hg. 50 Hz.
<b>Horsepower (Each Pump)</b>	10 HP
<b>Horsepower (Total System)</b>	20 HP
<b>Available Voltage</b>	208/230/460 v. 3 phase 60 Hz. 380 v. 3 phase 50 Hz. Contact Factory for other voltages
<b>Full Load Amps 3 ph.</b>	208 volts: 62.8 230 volts: 57.1 380 volts: 34.8 460 volts: 28.6
<b>Tank Size</b>	120 gallon vertical
<b>Medical Filter Bank (option)</b>	BOM-MED FB-2



Click here for pump specifications and industry-leading parts support.

\*System capacity is stated with one pump in reserve per NFPA. Capacity based on operation at sea level. For higher altitude, contact factory for adjusted capacity.

SYSTEM MODEL NO.	PART NO.	HP EACH	SCFVA/CPM @ 1" HP EACH	SCFVA/CPM @ 2" HP EACH	DESIGN CAPACITY (81" HP EACH)	RECEIVER SIZE (GALLONS)	PUMP INLET NPT	ESTIMATED SYSTEM WEIGHT (LB)	NOISE LEVEL (dBA)
C1000-873	SC1000-460-S2-V120	10	78 / 208	31.5 / 189	75	120	2"	2100	77

TABLE 1  
SYSTEM LISTED ARE 460V. IF ANOTHER VOLTAGE IS REQUIRED, USE THE FOLLOWING PART NUMBERS.

VOLTAGE	SYSTEM PIN	PUMP MODULE PIN	MOTOR OVERLOAD PROTECTION
208-40-3	SC1000-208-S2-V120	100-0133	214539
230-40-3	SC1000-230-S2-V120	100-0133	214539
380-50-3	SC1000-380-S2-V120	100-0133	214529

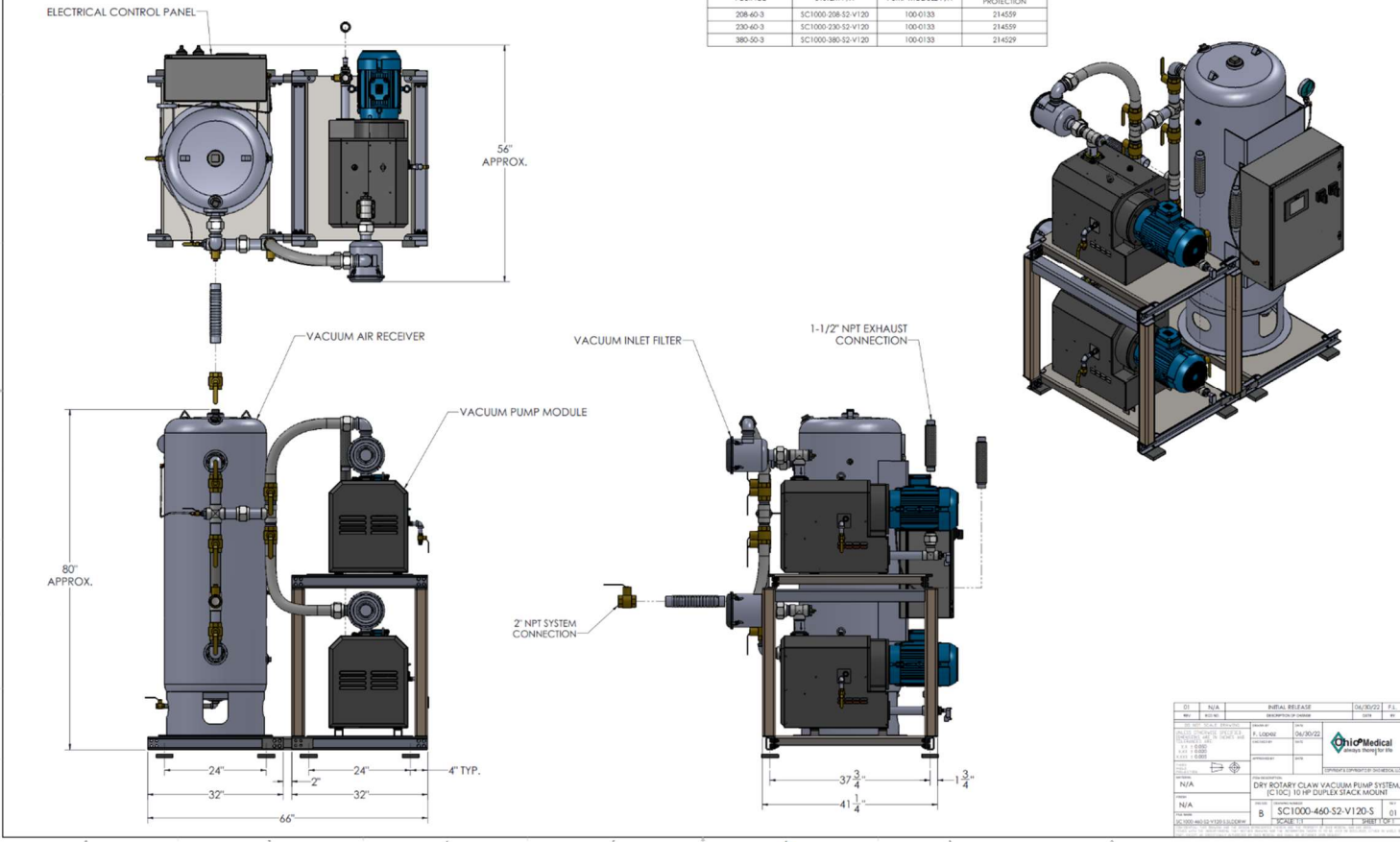

REV	QTY	PART NUMBER	DESCRIPTION	REF. NOTE
1	1		DRY ROTARY CLAW VACUUM PUMP SYSTEM (120) 10 HP DUPLEX STACK MOUNT	
2	1	SC1000-460-S2-V120-S		

